

Equipotential circuit - connect indicator, power supply and frame with the platform.

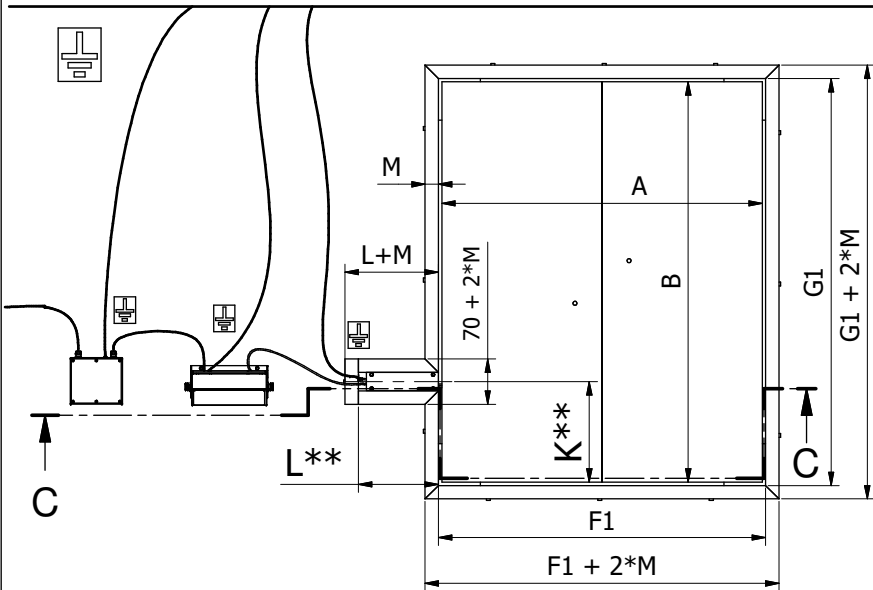

Caution!!!

The requirement for safe usage of the pit version scale is grounding the scale and the frame.

Permissible grounding resistance lower than 100Ω.

K, L** - the option of customization of dimensions to individual customer requirements**

Safety Precautions

The HX5-EX-x.4.xxxx.Hx/Z scales, due to the design of the platform and used material, can be operated in EX zones 1 and 2 endangered with explosion of gas-air mixture (vapour, mist, gas) of group IIA or IIB and of temperature class T1, T2, T3, T4.

Pit intended for the HX5-EX-x.4.xxxx.Hx/Z scale must adhere to all requirements of EX zone 1 and 2.

If there is a risk of hazardous area occurrence caused by air-gas mixture (vapour, mist), where the gas is heavier than the air, it is necessary to provide ventilation or other solution aiming to prevent potential occurrence of danger of explosion in the pit.

Caution! Areas where there is a risk of explosion are divided into zones and have been defined in Appendix no.1 of Directive 99/92EC. It is the investor, building designer and the end user who are responsible for evaluation and classification of the EX area (place intended for the pit).

HX5-EX-x.4.xxxx.Hx/Z scales					
1	2	3	4	5	6
Scale type	HX5-EX-x.4.150.H6/Z HX5-EX-x.4.150/300.H6/Z HX5-EX-x.4.300.H6/Z HX5-EX-x.4.300/600.H6/Z HX5-EX-x.4.600.H6/Z	HX5-EX-x.4.150.H7/Z HX5-EX-x.4.150/300.H7/Z HX5-EX-x.4.300.H7/Z HX5-EX-x.4.300/600.H7/Z HX5-EX-x.4.600.H7/Z HX5-EX-x.4.600/1500.H7/Z HX5-EX-x.4.1500.H7/Z	HX5-EX-x.4.300/600.H8/Z HX5-EX-x.4.600.H8/Z HX5-EX-x.4.600/1500.H8/Z HX5-EX-x.4.1500.H8/Z	HX5-EX-x.4.600.H8/9/Z HX5-EX-x.4.600/1500.H8/9/Z HX5-EX-x.4.1500.H8/9/Z	HX5-EX-x.4.600.H9/Z HX5-EX-x.4.600/1500.H9/Z HX5-EX-x.4.1500.H9/Z
Weighing pan (AxB)	800x800	1000x1000	1200x1200	1200x1500	1500x1500
F1xG1	824x824	1024x1024	1224x1224	1224x1524	1524x1524
H	90	90	90	90	90
M	40	40	40	40	40
1	2	3	4	5	
Scale type	HX5-EX-x.4.1500/3000.H8/Z HX5-EX-x.4.3000.H8/Z	HX5-EX-x.4.1500/3000.H8/9/Z HX5-EX-x.4.3000.H8/9/Z	HX5-EX-x.4.1500/3000.H9/Z HX5-EX-x.4.3000.H9/Z	HX5-EX-x.4.1500/3000.H10/Z HX5-EX-x.4.3000.H10/Z	
Weighing pan (AxB)	1200x1200	1200x1500	1500x1500	1500x2000	
F1xG1	1224x1224	1224x1524	1524x1524	1524x2024	
H	114	114	114	114	
M	50	50	50	50	
1	2	3			
Scale type	HX5-EX-x.4.3000/6000.H9/Z HX5-EX-x.4.6000.H9/Z	HX5-EX-x.4.3000/6000.H10/Z HX5-EX-x.4.6000.H10/Z			
Weighing pan (AxB)	1500x1500	1500x2000			
F1xG1	1524x1524	1524x2024			
H	168	168			
M	50	50			