

User Manuals

Analogue Output Module AP2



- AP2-1
- AP2-3



**MANUFACTURER OF ELECTRONIC
WEIGHING INSTRUMENTS**

RADWAG 26 – 600 Radom 28 Bracka Street - POLAND
Phone +48 48 384 88 00, phone/fax. +48 48 385 00 10
Sales department +48 48 366 80 06
www.radwag.com

Table of contents

1. PREVIEW	3
2. TECHNICAL PARAMETERS	3
2.1. Rating	3
2.2. Dimensions.....	4
3. RS 232 INTERFACE	5
4. CONNECTING A RECEIVER	6
5. SCALE SETTING FOR COOPERATING WITH THE AP2 MODULE	6
6. PROGRAMMING THE AP2 MODULE	7
6.1. Indicators that can cooperate	7
6.2. Work modes	8
7. COMPUTER PROGRAM “4-20mA current loop”	9
8. DEFECTS	12
9. APPENDIX	12
9.1. The PUE C/31 configuration for cooperation with module AP2.....	12
9.2. The PUE 7 configuration for cooperation with module AP2	13

1. PREVIEW

An **AP2** 4–20mA current loop module made in **RADWAG** has been designed to convert digital value of mass to analogue current value. It can cooperate with scales of **RADWAG** production and should not be used with devices of other producers. It is a passive module that needs external voltage **24VDC** to work properly.

It can work in three modes showing:

- Absolute value (no sign),
- Only positive values,
- Both negative and positive values.

The AP2 modules have two versions of implementation:

- **AP2-1** in plastic casing is designed to cooperate with weighing indicators **PUE C/31** and **PUE 7**. It is supplied from an external power adapter **230V/5V DC** which is attached to each module. The current circuit is led out using a dual core cable of **1.7m** length. Interface **RS232** is led out using a cable of **1.7m** length terminated with plug **DB9/F**;
- **AP2-3** in metal housing is designed to cooperate with weighing indicators **PUE C/31H**. It is supplied from the weighing indicator. The current circuit is led out using a dual core cable of **1.7m** length. Interface **RS232** is led out using a cable of **2m** terminated with female plug **M12**.

Notice:

AP2-3 modules are accessible only in a set with the indicator.

2. TECHNICAL PARAMETERS

2.1. Rating

	AP2-1	AP2-3
Housing	Plastic	Stainless steel
Power supply	Adapter 230V AC/ 5V DC 500mA	from PUE C/31H indicator
Current circuit supply	External constant-voltage power supplier 24VDC (min 50mA)	

Power dissipation	450mW	
Max load resistance	500Ω	
Output resolution	16 Bits	
Linearity error	+/- 0.01 %	
Indication error for 4mA (+25C)	+/- 0.1 %	
Indication error for 20mA (+25C)	+/- 0.2 %	
Temperature error for 4mA	+/-25 ppm/°C	
Temperature error for 20mA	+/-50 ppm/°C	
Operation temperature range	-10°C to +40°C	
Output current cable	1,7m	
RS232 cable	1,7m with DB9/F plug	2m with M12 female plug
Dimensions (mm)	68 x 35 x 129	146x49x104
Weight	~475g	~1.15kg

2.2. Dimensions

- **AP2-1 analogue output module:**

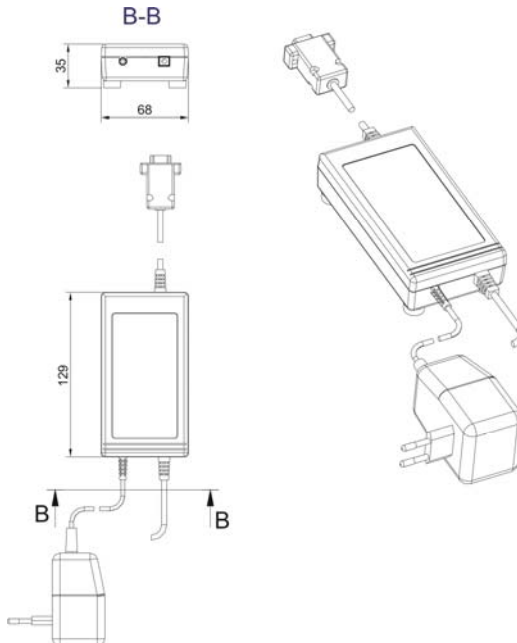

- **AP2-3 analogue output module:**

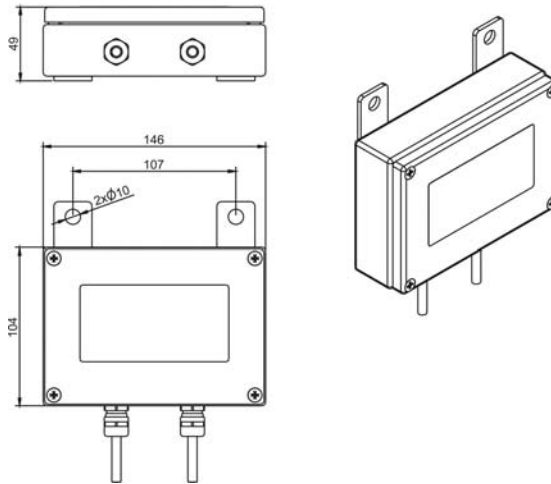

3. RS 232 INTERFACE

The **RS232** interface connectors of the **AP2** analogue output module:

- **DB9/F** in version **AP2-1** of the module,
- **M12 female** in version **AP2-3** of the module.

The **DB9/F** connector is designed to connect the **AP2-1** analogue output module both to the computer and weighing indicators **PUE C/31**, **PUE7**.

Scale
DB9/F Connector (femate)

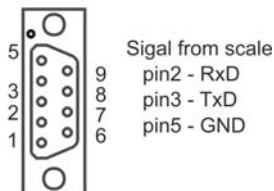

Signals on DB9/F

The **M12 female** connector is designed to connect the **AP2-3** analogue output module to weighing indicators **PUE C/31H** only.

RS 232 transmission parameters:

Baud rate	9600
Number of data bits	8
Parity	No
Stop bits	1
Flow control	No

Notice:

It is not possible to change these parameters so please use indicator parameters to set it according the module demands.

4. CONNECTING A RECEIVER

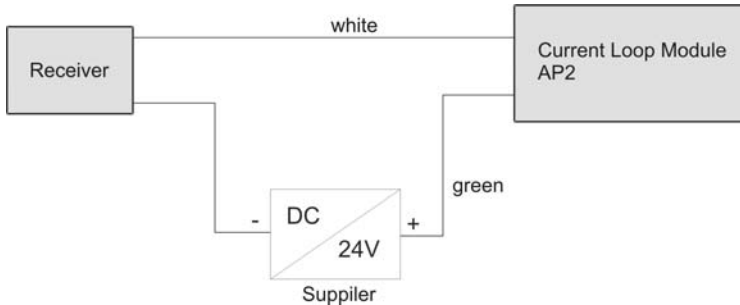

5. SCALE SETTING FOR COOPERATING WITH THE AP2 MODULE

In order to set the proper cooperation scale-module, please set following parameters in an indicator:

- Set transmission parameters of RS 232 according to the table in p. 3 of this manual,

- Enable continuous transmission and / or choose an appropriate printout pattern depending on the indicator.

Notice:

*In **APPENDIX** the configurations' description for the most popular indicators (PUE C/31, PUE 7) has been placed.*

6. PROGRAMMING THE AP2 MODULE

The module requires a proper setting of the following parameters:

- Indicator type,
- Work mode,
- Maximal range of a scale.

If a module has been ordered and purchased together with a scale it is to be configured to cooperate with the scale. Otherwise a module needs proper setting beside the firm.

It can be made by using a program that is attached to the converter - see chapter 7.

6.1. Indicators that can cooperate

Following indicators can cooperate with the module:

- PUE C3
- PUE 1/5
- PUE C30
- PUE C/31
- PUE 4
- PUE 7
- HTX
- WTX
- WLT-L

6.2. Work modes

A user can define one of the three work modes that determine the current output behaviour:

I. Module shows absolute value according to the chart below:

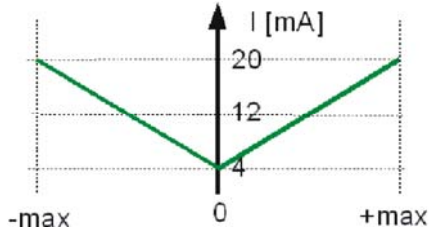

This mode is set in the factory

The value 4 mA is related to mass value equal 0, however the value 20 mA can be related both to mass values equal [- max] or [+ max].

II. Module show values according to the chart below:

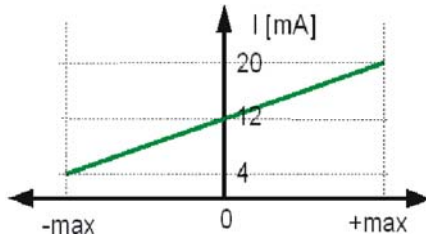

Value 4 mA is related to [-max] value

Value 12mA is related to [0]

Value 20 mA is related to [+max]



Resolution is divided in to parts for two intervals <max, 0> and <0, max>.

III. Module show values according to the chart below:

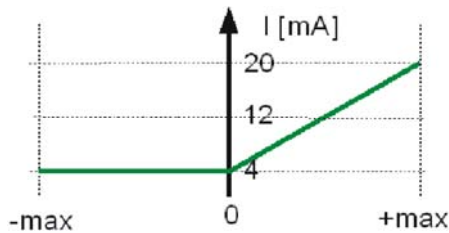

Value 4 mA is related to $[-max] \div [0]$ values

Value 20 mA is related to $[+max]$ value

7. COMPUTER PROGRAM “4-20mA current loop”

Computer program “4-20mA current loop” gives the possibility to configure and test a 4-20mA current loop module.



Please connect a module to your computer first and run the attached program.

Main window:

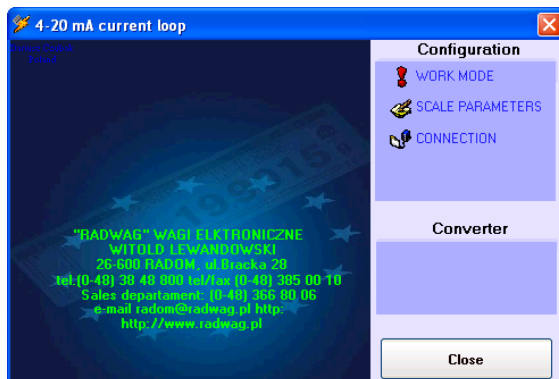

Click the **Work mode** menu item to reach a configuration window in order to set module parameters.

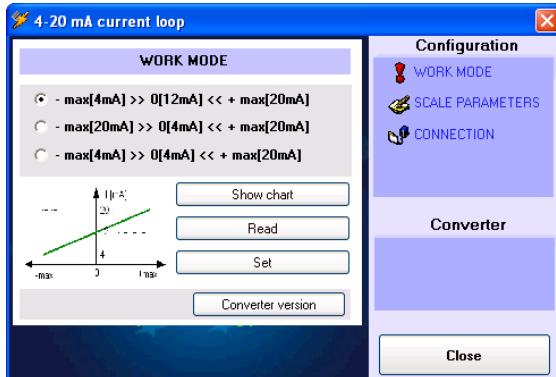

Select the expected work mode and click on the **<Set>** button.



You can also check the work mode that has been set. Click the **<Read> button in order to read out this information.**

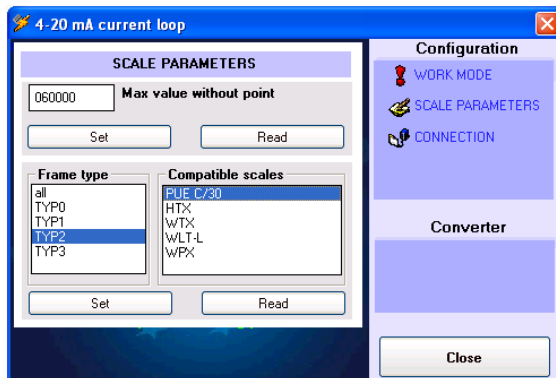

Click the **<Scale parameters>** menu item to set an indicator type and the maximal range of a scale.

After inscribing the maximal value click **<Set>** button to save settings in the module.



The point should be omitted while inscribing the maximal value e.g.

weighing capacity = 10.00 kg inscribe 1000

weighing capacity = 3.000 kg inscribe 3000

weighing capacity = 6000 g inscribe 6000

The next step is to select an indicator type. Indicators/terminals of **RADWAG** production uses different transmission protocols so that current loop module needs to be adjusted to understand the protocol.

<**Frame type**> window is designed for a handy change of the active frame.

Select a communication port number and port parameters, using <**Connection**> window, according to the table from the chapter 3.

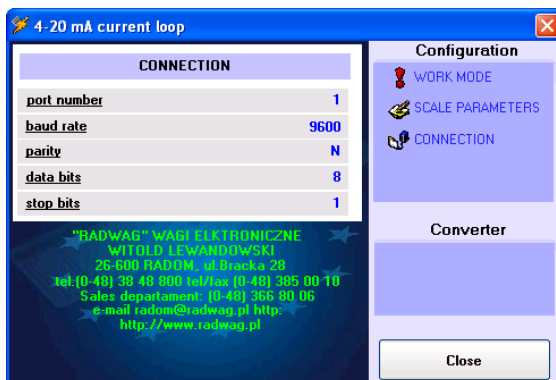

8. DEFECTS

Lack of current signal from the analogue output	Check polarization of the circuit Check presence of 24VDC Check power supply 230VAC
Constant 4 mA on the output	Wrong output configuration Wrong baud rate value set in an indicator Check setting continuous transmission in an indicator Broken connection indicator – module
Current increment not proportional to the mass increment	Error in module configuration – wrong scale range set
Lack of communication with computer program	Check power supply 230VAC Check connection RS 232
Message in computer program „Port in use” or similar	The selected COM port is used by another application

9. APPENDIX

9.1. The PUE C/31 configuration for cooperation with module AP2

- **Setting the type of printout**

Path	Parameter
Setup / P2.Prnt / 2.1.Pr_n	CntA

- **Setting of serial transmission parameters**

Path	Parameter
Setup / P2.Prnt / 2.3.bAud	9600
Setup / P2.Prnt / 2.4.S_rS	8d1SnP

9.2. The PUE 7 configuration for cooperation with module AP2

- **Communication port settings**

Path	Parameter
Setup / Parameters / Devices / Additional display / Port	COM 1

- **Printout pattern setting**

Path	Parameter
Setup / Parameters / Devices / Additional display / Sample	SI {0} – as a code entered using the screen keyboard

- **Serial transmission parameters setting**

Path	Parameter
Setup / Parameters / Communication / COM 1 / Baud Rate	9600
Setup / Parameters / Communication / COM 1 / Data bits	8
Setup / Parameters / Communication / COM 1 / Stop Bits	1
Setup / Parameters / Communication / COM 1 / Parity	None

MANUFACTURER
OF ELECTRONIC WEIGHING INSTRUMENTS



RADWAG Wagi Elektroniczne
26 – 600 Radom, 28 Bracka Street
POLAND
Phone +48 48 38 48 800, phone/fax. + 48 48 385 00 10
Sales Department + 48 48 366 80 06
www.radwag.com



DIN EN ISO 9001:2000
CERTIFICATE NO 71 100 C206