

INFLUENCE OF MEASURING PROCESS AUTOMATION ON UNCERTAINTY OF MASS STANDARD AND WEIGHTS CALIBRATION.

The article presents the influence of comparison process automatization of mass standards and weights on measuring uncertainty while determining mass of standards and weights.

Based on tests of selected types of manual and automatic mass comparators of the same metrological characteristics featuring the same capacity and readability, instrument's repeatability has been determined, which have considerable contribution in the measuring uncertainty budget during calibrating mass standards and weights.

The measurements have been carried out in the same ambient conditions, characteristic to calibrating mass standards and weights of the highest accuracy class (E_1 and E_2).

INTRODUCTION

... "there are no accurate measurements in nature"... such thesis is accepted by everyone who works with any type of measurements – starting from measurements carried out by children in primary schools, through measurements performed in "households" or industrial areas, and finally advanced measuring processes carried out in research and scientific centers. Presently we have access to even more accurate measuring equipment, which in majority apply digital technology.

Dynamic development of electronics caused revolutionary changes in the design and means of operation of measuring instruments, including balances and scales. Presently a common instruments dedicated for mass measurement processes are widely conceived electronic weighing instruments. An inseparable concept related to weighing instruments is a weight. Its role evolved through time, but today its concept has significantly changed. Today mass standards and weights, in majority of cases, are used for calibration and/or checking or electronic balances and scales. Previous function of weights, i.e. compensation of once common pan scales, has practically disappeared.

A basic tool indispensable for calibration of weights, apart from mass standards, is a mass comparator, which enables comparing mass (of tested and reference standard) with very high resolution.

1. Metrological parameters of mass comparators

Mass comparators are devices designed for determination of the difference between mass of a tested mass standard (B) and known mass of a reference standard (A). Mass comparators are most commonly used in measuring laboratories for calibration of mass standards and weights and different types of technological weights.

The accuracy of mass comparator is strongly influenced by ambient conditions (ambient air temperature and relative humidity and their change over time, any type of air movement and turbulence, and vibrations of external source). Minimum ambient conditions (temperature and humidity) for carrying out calibration process are clearly determined in the OIML R-111 Document (Attachment C p. C.2.1. Table C.1)

In order to ensure correct carrying out of measuring process, the mass comparators have to be equipped with system controlling the ambient conditions at a workstation (air temperature and relative air humidity). A workstation should be stable and free from any type of vibrations.

Although mass comparators are not subject to legal metrological control, nor standard EN 45501 applies to them directly, the basic metrological characteristics can be defined on basis of above mentioned standard.

Reading unit (readability) d , which is defined in point T.3.2.2 of standard EN 45501 is a value of difference between two corresponding indications of the scale in analog indication. In digital indication, a value of difference between two corresponding indications.

Maximal capacity Max (p. T.3.1.1) is the maximum possibility of measuring without applying the limit of tarring device. In case of a mass comparator, it is the maximum mass that is calibrated on a given mass comparator.

Repeatability according to the international vocabulary of basic and general terms in metrology (VIM) it is the measurement precision under repeatability conditions of measurement. According to definition T.4.3 described in Standard EN 45501 repeatability is a property of a measuring system to provide closely similar indications while the same load is placed for several times on a weighing pan, under repeatability conditions and possibly in the same testing conditions.

Repeatability, expressed quantitatively in terms of standard deviation is the most important metrological parameter of a mass comparator.

Standard deviation of a mass comparator is determined for the difference of indications (r) between a tested weight (B) and reference standard (A) in a determined quantity of ABBA or ABA measuring series n .

Standard deviation of a mass comparator is calculated using below equation:

$$s = \sqrt{\frac{\sum_{i=1}^n (r_i - \bar{r})^2}{n-1}} \quad (1)$$

where - r_i – difference of averages B - A i -of a given measurement

\bar{r} – arithmetic mean of the differences for n measuring results

Difference of indications r_i for the ABBA method and for each i series of measurements is determined from a relation:

$$r_i = \bar{B} - \bar{A} \quad (2)$$

where: \bar{B} is the average indication for a tested weight in a given i ABBA series
 \bar{A} is the average indication for control standard in a given i ABBA series

The value of differences r_i is calculated from a relation:

$$\bar{r} = \frac{1}{n} \times \sum_{i=1}^n r_i \quad (3)$$

where: n – number of measurements (ABBA or ABA series)

Standard deviation is the most often used acceptance criterion of a mass comparator in calibration and/or checking. It is also specified in product folders provided by mass comparator's manufacturers.

Below is an instance of repeatability calculation process for a mass comparator WAY 5/KO series with maximum capacity *Max* 5 kg and reading unit $d = 0,1$ mg which is dedicated for calibration and/or checking of weights with nominal mass 1 kg, 2 kg and 5 kg. The process covered 6 measuring series ABBA for the 1 kg load with application of two mass standards. Then, for the average indication B and A , calculation of the difference between the tested and control standards in each of measuring series has been carried out using an equation (2). Obtained results are demonstrated in below Table 1:

No.	<i>A - control</i> [g]	<i>B - tested</i> [g]	<i>B - tested</i> [g]	<i>A - control</i> [g]	r_i [g]
1	0,0000	1,0001	0,9998	-0,0003	1,00010
2	-0,0003	0,9999	0,9999	-0,0004	1,00025
3	-0,0006	0,9995	0,9996	-0,0005	1,00010
4	-0,0004	0,9998	0,9996	-0,0004	1,00010
5	-0,0002	1,0000	0,9999	-0,0002	1,00015
6	-0,0005	0,9997	0,9999	-0,0005	1,00030

Table 1 Measurement results of 1 kg load

Based on equation (3) the average value r_i has been calculated and obtained result is 1,000167 g. Use the equation (1) enabled calculating standard deviation for the 6 differences r_i and obtained result is 0,09 mg, which is the parameter of mass comparator's repeatability.

Electric compensation range it is the operation range of a measuring instrument in which the measurement process (measuring range) takes place. A typical electric compensation range of a mass comparator differs from electric compensation range of a balance. The difference is indicated on below figure:

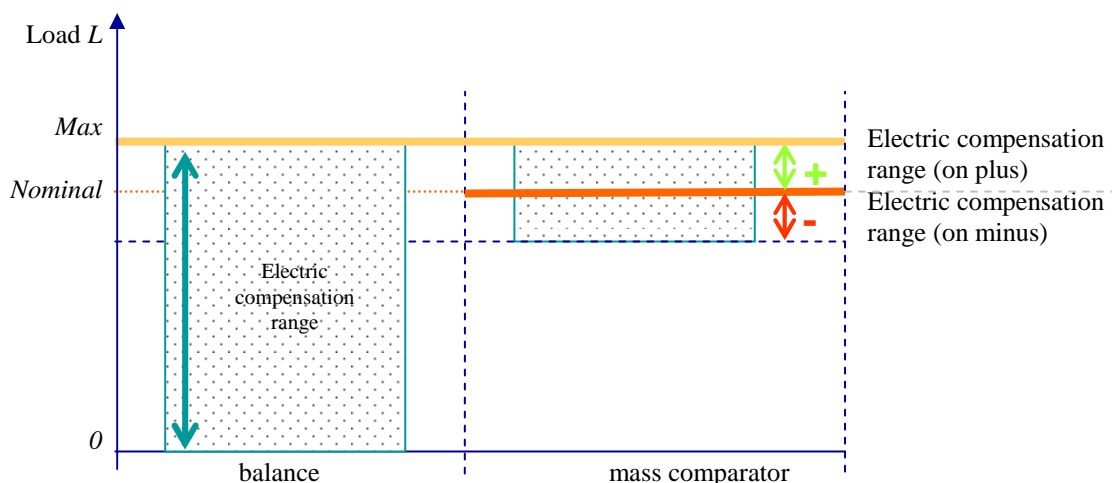

Fig. 1 comparison of electric compensation range of a balance and a mass comparator

As visible on the figure 1, the electric compensation range of a standard balance covers area from 0 to the maximum capacity – i.e. the full measuring range. The electric compensation range is limited, and depends on mass comparator’s design. It is characterized by the fact, that the measurement can be carried out below or above the nominal value of the tested weight. It is particularly important in case of calibrating weights, due to use of a weighing instruments such as a mass comparator for comparison of mass. This solution additionally enables for measuring large mass with very high accuracy and very accurate repeatability.

3. Ambient conditions in a calibration laboratory

Maintaining an appropriate level of local and ambient conditions in a laboratory calibrating mass standards and weights is indispensable for obtaining reliable calibration results. international recommendations specified in the Document OIML R111 provide maximal permissible temperature and humidity values in relation to accuracy class of calibrated mass standards and/or weights.

Weight’s accuracy class	Change ratio of temperature during calibration	
	Within 1 hour	Within 12 hours
E1	± 0,3 °C	± 0,5 °C
E2	± 0,7 °C	± 1,0 °C
F1	± 1,5 °C	± 2,0 °C
F2	± 2,0 °C	± 3,5 °C
M1	± 3,0 °C	± 5,0 °C

Table 2-1 Requirements on ambient conditions in a laboratory –air temperature (in accordance with Document OIML R 111)

Weight's accuracy class	Change ratio of humidity during calibration	
	Humidity range	max. per 4 hours
E1	from 40 % to 60 %	± 5 %
E2		± 10 %
F1		± 15 %

Table 2-2 Requirements on ambient conditions in a laboratory – relative air humidity
(in accordance with Document OIML R 111)

As demonstrated by the requirements of the Document R 111, a mass comparator in use should operate correctly within the specified range of ambient conditions given in the tables appropriately for the accuracy class of tested standard. In some cases there may be a need to limit the conditions, if metrological parameters of a mass comparator impair with change of ambient temperature or humidity. Such case can only be detected by an appropriate test in the place of use.

3. Determining repeatability parameter of a mass comparator in manual and automatic work cycle

RADWAG Laboratory carried out a series of tests on mass comparators' repeatability by determining standard deviation for a given n number of ABBA and ABA cycles. The tests were carried out on the same objects in manual and automatic mode.

3.1 Tested objects

The subject of the tests were mass comparators manufactured by RADWAG

Test object no. 1: Mass comparator WAY 500/2Y/KO

- Max capacity 510 g
- Readability $d = 0,01$ mg
- Electric compensation range ± 10 g
- Repeatability (6 ABBA cycles) 0,02 mg
- Range of calibrated mass 100 g, 200 g, 500 g
- Substitution weights internal

Test object no. 2: Mass comparator WAY 1/2Y/KO

- Max capacity 1000 g
- Readability $d = 0,01$ mg
- Electric compensation range ± 10 g
- Repeatability (6 ABBA cycles) 0,05 mg
- Range of calibrated mass 200 g, 500 g and 1000 g
- Substitution weights internal



Fig.2 Mass comparator WAY 500/2Y/KO series

Basic components of a mass comparator
WAY 500/2Y/KO and
WAY 1/2Y/KO series

1 – ambient conditions sensor

2 – mechanical measuring system with electromagnetic converter

3 – a knob for applying internal substitution weights

4 – terminal

Test object no. 3: Mass comparator APP 20/2Y/KO

- | | |
|---------------------------------|--------------|
| ▪ Max capacity | 20 kg |
| ▪ Readability | d = 1 mg |
| ▪ Electric compensation range | ± 500g |
| ▪ Repeatability (6 ABBA cycles) | 2 mg |
| ▪ Range of calibrated mass | 10 kg, 20 kg |
| ▪ Substitution weights | internal |

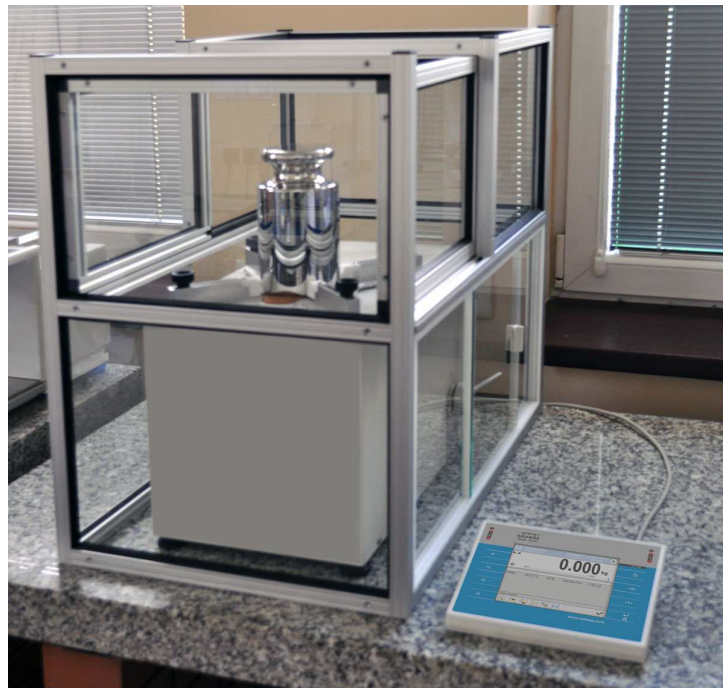

Fig. 3 Mass comparator APP 20/2Y/KO series

The mass comparator features an aluminum weighing pan with cork layer and centering holders for the weights. On a side of mass comparator's housing there is a two-way switch for applying internal substitution weights. The weighing chamber has openable top glass door for loading calibrated mass standards and weights.

3.2 Measuring procedure

Manual tests

The procedure covered determining repeatability of a mass comparator for different number of ABBA and ABA cycles.

The difference of indications r_i in the ABBA method in each i measuring series is determined from a relation:

$$r_i = \bar{B} - \bar{A} \quad (4)$$

where: \bar{B} is the average indication of tested weight in a given i ABBA series

\bar{A} is the average indication of reference standard in a given i ABBA series

Based on the obtained differences, standard deviation is calculated from an equation:

$$s^2 = \frac{1}{n} \sum_{i=1}^n (r_i - \bar{r}_i)^2 \quad (5)$$

$$\text{where: } \bar{r}_i = \frac{1}{n} \sum_{i=1}^n r_i \quad (6)$$

The difference of indications r_i in the ABA method in each i measuring series is determined from a relation:

$$r_i = B - \bar{A} \quad (7)$$

Based on the obtained differences, standard deviation is calculated from an equation (5)

In the ABBA method the determined measurements in the ABBA series are for 2, 3, 4, 5, 6, 10 and 20 cycles, and in the ABA method – 2, 3, 4, 5, 6, 7, 8, 9, 10 and 20 cycles.

Automatic tests

In the automatic cycle repeatability of mass comparators has been determined for the same quantity of ABA and ABBA cycles as in case of manual tests.

3.3 Testing workstation:

3.3.1 Ambient conditions

Manual and automatic comparison tests of mass comparators have been carried out in RADWAG Testing Laboratory. Ambient conditions during carrying out all of the measurements were within the following limits:

- temperature $22,8\text{ °C} \div 23,4\text{ °C}$
- humidity $46 \div 55\%$,

During tests it has not been found, that dynamics of the above values was exceeding the limits specified in the Document R-111 OIML for accuracy class E_1 – see point C2. General requirements.

All test rooms in which the tests were carried out feature a control system of automatic ambient temperature and humidity with online monitoring and recording. An instance of results of ambient conditions monitoring process carried out with Ambient Conditions Monitor and RWS sensors, offered by RADWAG, is presented on fig. no. 4.

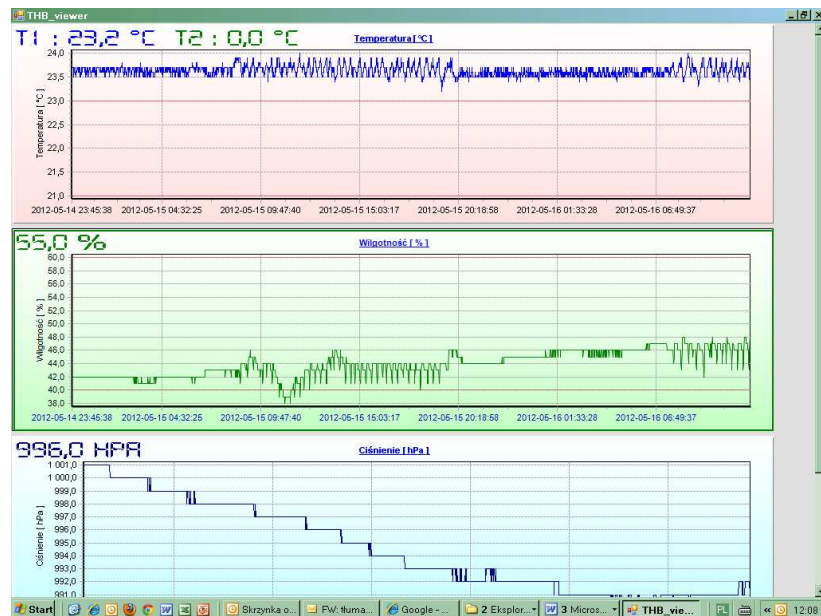

Fig. 4 An instance of ambient conditions monitoring results using the RWS Monitor.

3.3.2. Measuring workstation for manual mass comparison

The laboratory room in which the measurements were carried out is located on floor “0”. The foundation of testing console is separated from the foundation of the building + for eliminating vibrations of the ground.

The workstation features:

1. ambient conditions controlling system
2. mass comparator APP 20/2Y/KO series
3. mass comparator WAY 1/2Y/KO series
4. mass comparator WAY 500/2Y/KO series



Fig. 5 Measuring workstation for manual testing of a mass comparator

3.3.3. Application of internal substitution weights in comparison process of weights

During mass comparison process each weight is compensated to status “0”. In practice, it stands for a necessity to apply substitution weights for compensating the mass comparator. All tested objects featured a semi-automatic substitution weights applying system. It is realized through substitution weights internally assembled in mass comparators’ housings. Selection of compared mass is clearly marked.



WAY 500/2Y/KO



WAY 20/2Y/KO

Fig. 6 Determination of compared mass on a mass comparator

3.3.4. Measuring workstation for automatic mass comparison

Testing mass comparators’ repeatability in the automatic operation mode has been carried out in the control and research room for high resolution balances, in the RADWAG company on level “0”. The testing rooms, similarly to the Laboratory rooms, are equipped with system for controlling ambient conditions parameters (ambient temperature, relative ambient humidity) and ambient conditions monitoring device (air temperature, relative air humidity and atmospheric pressure). Ambient conditions in both rooms are pre-set at the same level, and they are subject of continuous monitoring. Each of automatic mass comparators is placed on a special anti-vibrating base, located in the bottom section of the mass comparator.

Scheme of a mass comparator AKM -2/20 series

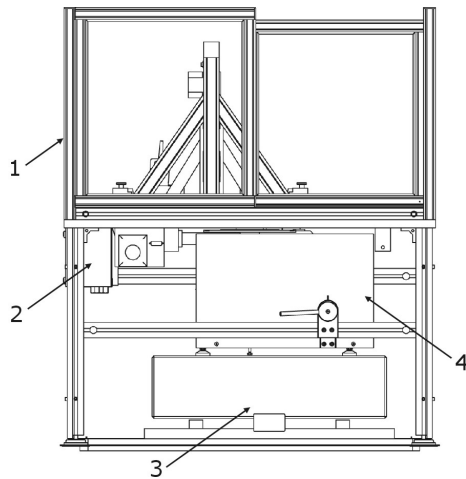

1 – anti-draft shield of the mass comparator
(glass design with manually opened glass doors)

2 – automatic control system
(control of weights cyclic loading and unloading process)

3 – anti-vibrating basis of the mass comparator (isolation from vibration of the ground)

4 – mass comparator WAY 20/2Y/KO series

Fig. 7 Workstation for automatic mass comparison AKM -2/20 – general design

Scheme of a mass comparator AKM – 4 series

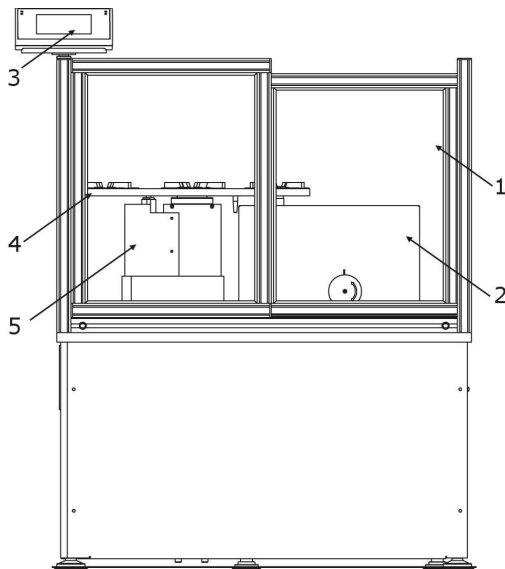

1 – anti-draft shield of the mass comparator
(glass design with manually opened glass doors)

2 – mass comparator WAY 500/2Y/KO series

3 – mass comparator's terminal with panel

4 – seats for weights and mass standards

5 – automatic control system
(control of weights cyclic loading and unloading process)

Fig. 8 Workstation for automatic mass comparison AKM -4/500 – general design

The workstation features:

1. four-position automatic loading robot for mass comparators AKM-4 series with installed mass comparator WAY 500/2Y/KO series (or interchangeably WAY 1/2Y/KO) and assembled ambient conditions module THB-2 series for monitoring the ambient conditions
2. two-position automatic loading robot for mass comparators AKM-2 series with installed mass comparator APP 20/2Y/KO series and assembled ambient conditions module THB-2 series for monitoring the ambient conditions
3. a PC computer with ambient conditions monitoring device RWS

A measuring workstation is presented below on figure no. 9.



Fig.9 Measuring workstation for automatic testing of mass comparators

3.4 Test results

As a result of carried out measurements in accordance with described measuring procedure, the test provided parameter of repeatability for each of the mass comparators using manual and automatic method and different tested loads. The results are presented below in tables and charts.

Mass comparator WAY 500/2Y/KO series

ABBA METHOD						
Number of cycles	Load					
	100 g		200 g		500 g	
	manual [mg]	automatic [mg]	manual [mg]	automatic [mg]	manual [mg]	automatic [mg]
2	0,0035	0,0265	0,0141	0,0000	0,0000	0,0124
3	0,0087	0,0142	0,0050	0,0109	0,0076	0,0208
4	0,0048	0,0113	0,0050	0,0043	0,0119	0,0130
5	0,0067	0,0053	0,0067	0,0034	0,0084	0,0073
6	0,0080	0,0133	0,0027	0,0101	0,0061	0,0150
10	0,0041	0,0120	0,0092	0,0107	0,0125	0,0061
20	0,0122	0,0050	0,0116	0,0057	0,0106	0,0082
Average	0,00686	0,0125	0,00776	0,00644	0,00816	0,01183
Dispersion	0,0087	0,0215	0,0114	0,0109	0,0125	0,0147

Table 3. Measurement results with use of a mass comparator WAY 500/2Y/KO series and ABBA method

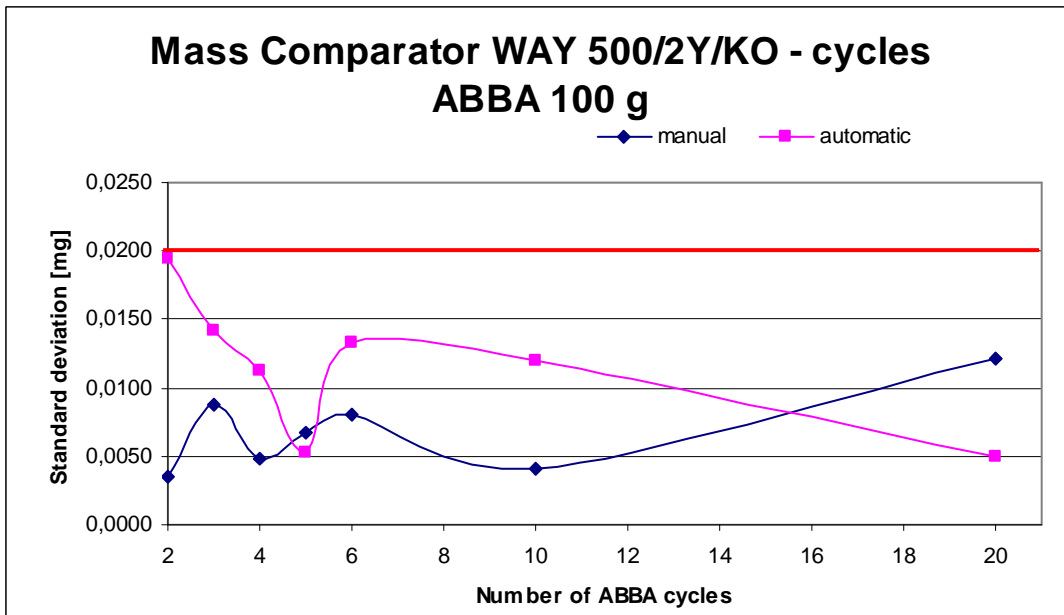

Fig. 10 Chart of standard deviation changes in relation to number of ABBA cycles – for mass 100 g

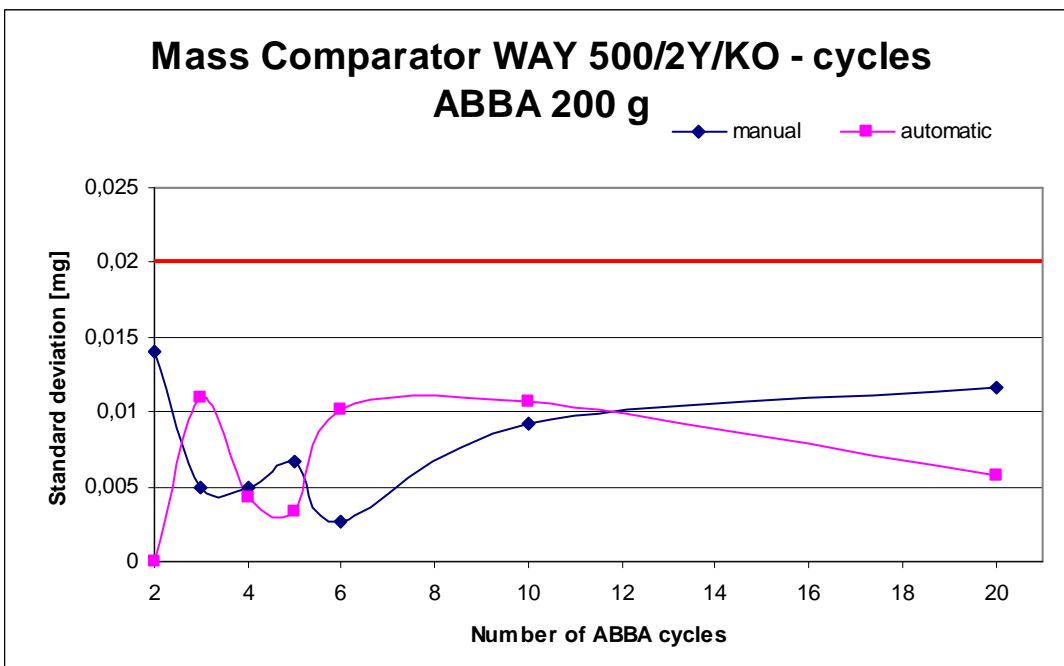

Fig. 11 Chart of standard deviation changes in relation to number of ABBA cycles – for mass 200 g

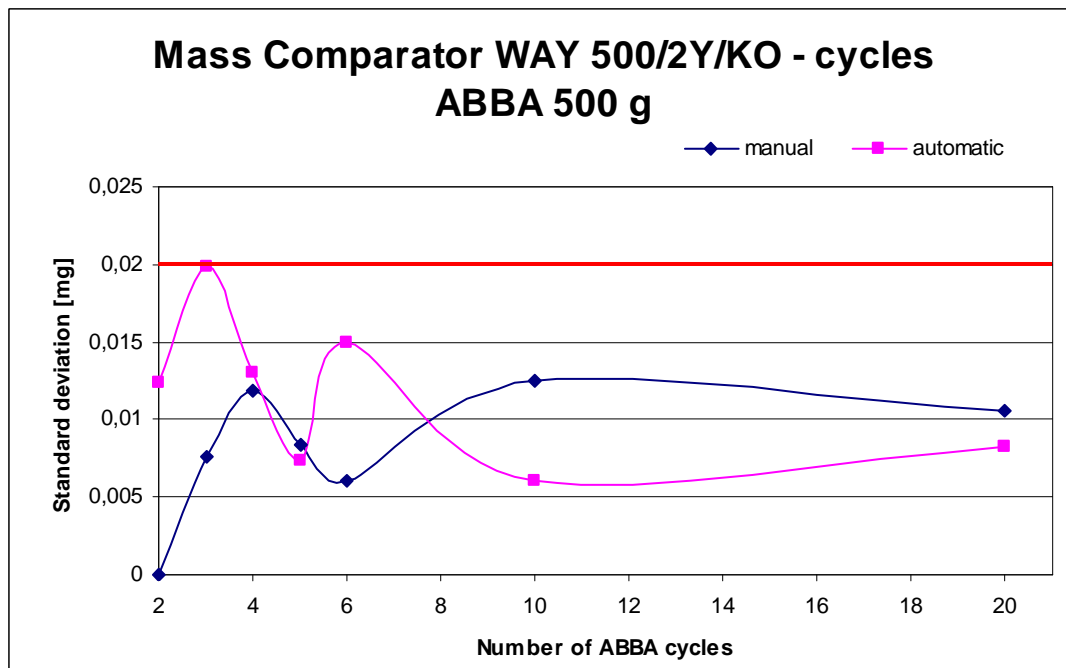

Fig. 12 Chart of standard deviation changes in relation to number of ABBA cycles – for mass 500 g

Analysis of obtained results enables stating, that the standard deviation determined for the ABBA cycles and the mass comparator WAY 500/2Y/KO series, both in manual and automatic operation mode is close to one another. Standard deviation value declared by the manufacturer is 0,02 mg. Thus, it can be observed, that in case of loads from 100 g to 500 g, mass comparator's operating mode does not considerably influence its repeatability. The optimal (the lowest) standard deviation is obtained for 100 g load and 10 measuring cycles in manual mode, and in the automatic mode for 5 measuring cycles. In case of 200 g load in the manual mode it is 6 measuring cycles, and in the automatic mode 5 measuring cycles. Different conclusions are drawn from measuring results of 500 g load, where in the manual mode the lowest standard deviation was obtained in 6 measuring cycles and in the automatic mode in 10 measuring cycles.

ABA METHOD						
Number of cycles	Load					
	100 g		200 g		500 g	
	manual	automatic	manual	automatic	manual	automatic
	[mg]	[mg]	[mg]	[mg]	[mg]	[mg]
2	0,0106	0,0071	0,0141	0,0141	0,0141	0,0053
3	0,0150	0,0063	0,0000	0,0038	0,0050	0,0101
4	0,0103	0,0052	0,0050	0,0105	0,0103	0,0055
5	0,0102	0,0032	0,0104	0,0049	0,0089	0,0040
6	0,0105	0,0083	0,0074	0,0061	0,0133	0,0070
7	0,0095	0,0151	0,0081	0,0056	0,0157	0,0200
8	0,0110	0,0098	0,0071	0,0102	0,0143	0,0090
9	0,0063	0,0050	0,0097	0,0076	0,0109	0,0223
10	0,0097	0,0098	0,0097	0,0053	0,0105	0,0110
20	0,0075	0,0075	0,0071	0,0074	0,0095	0,0126
Average	0,01006	0,0077	0,0786	0,00755	0,01125	0,01068
Dispersion	0,0087	0,0119	0,0141	0,0103	0,0107	0,0183

Table 4. Measurement results with use of a mass comparator WAY 500/2Y/KO series and ABA method

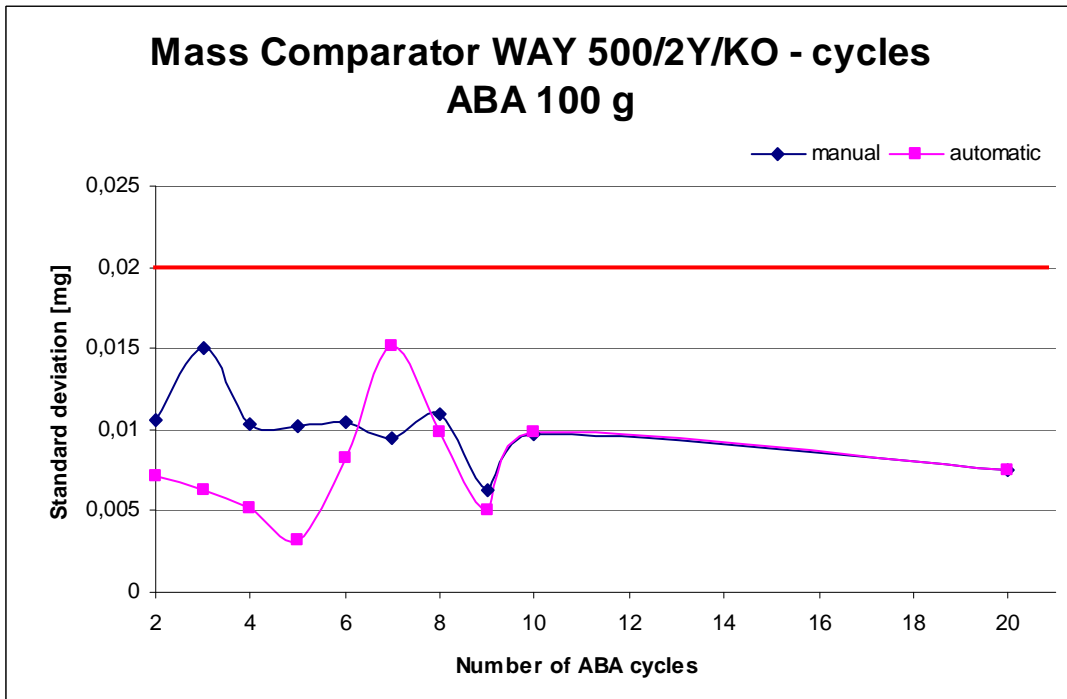

Fig. 13 Chart of standard deviation changes in relation to number of ABA cycles – for mass 100 g

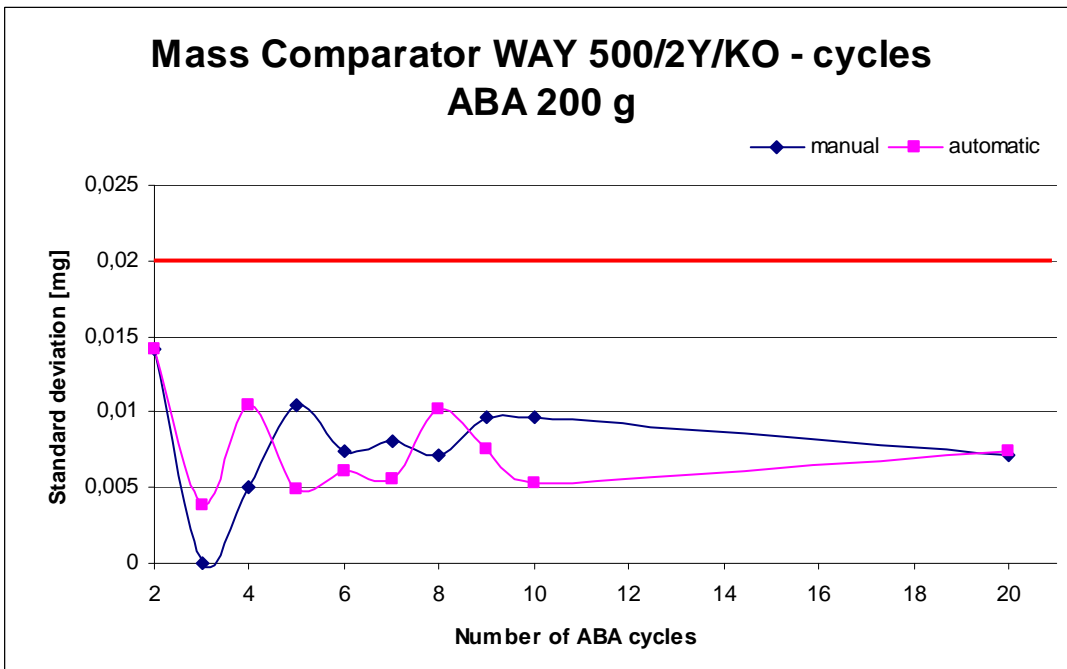

Fig. 14. Chart of standard deviation changes in relation to number of ABA cycles – for mass 200 g

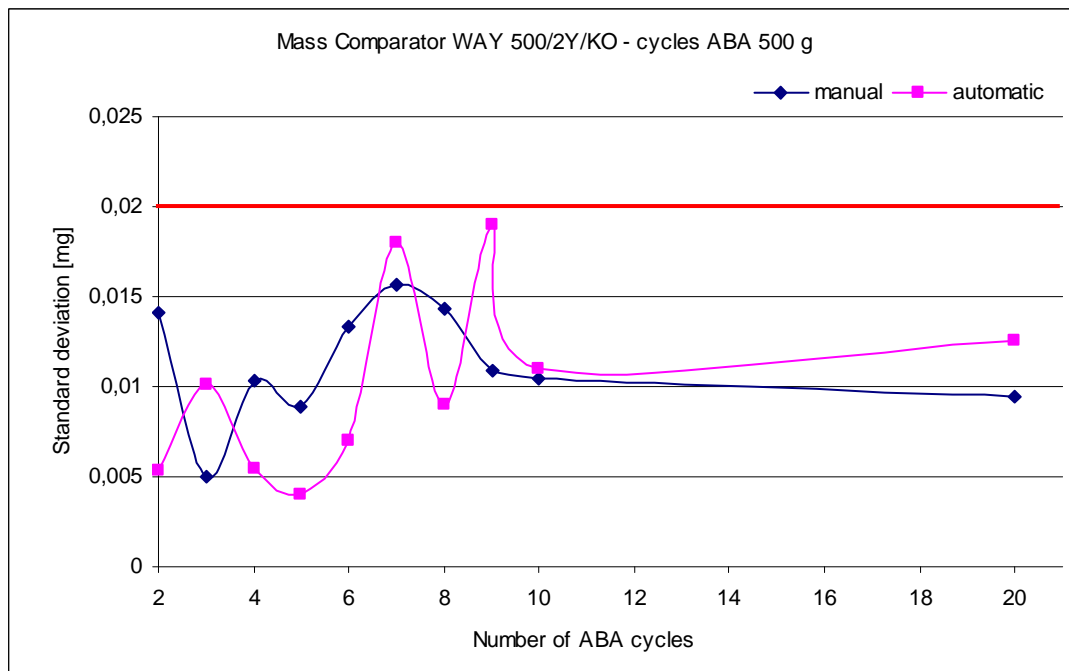

Fig. 15. Chart of standard deviation changes in relation to number of ABA cycles – for mass 500 g

Analysis of obtained results enables noting, that in case of ABA method, the lowest standard deviation in the manual mode and for 100 g load is in case of 9 measuring cycles, and in the automatic mode in 5 measuring cycles. In case of 200 g load, the best repeatability is obtained in the same quantity of measuring cycles, i.e. 3. The best repeatability for 500 g load and manual mode is in 3 measuring cycles, while in automatic mode in 5 ABA cycles.

In conclusion, while observing both measuring methods ABBA and ABA, it is noticeable, that in case of a tested mass comparator there is no difference in standard deviation value during manual and automatic operation mode. Though, it can be concluded, that in case of decreasing the reading unit (i.e. increasing accuracy of mass readout) the differences become visible and they are in favour of automatic operation mode.

Mass comparator WAY 1/2Y/KO series

ABBA METHOD						
Number of cycles	Load					
	200 g		500 g		1 kg	
	manual	automatic	manual	automatic	manual	automatic
	[mg]	[mg]	[mg]	[mg]	[mg]	[mg]
2	0,007	0,004	0,011	0,018	0,007	0,018
3	0,005	0,009	0,010	0,006	0,040	0,018
4	0,010	0,011	0,020	0,008	0,043	0,021
5	0,007	0,007	0,028	0,019	0,030	0,029
6	0,013	0,008	0,005	0,007	0,026	0,017
10	0,014	0,011	0,008	0,006	0,033	0,028
20	0,014	0,012	0,018	0,011	0,025	0,024
Average	0,00994	0,00886	0,01426	0,01071	0,02906	0,02214
Dispersion	0,009	0,008	0,023	0,013	0,036	0,012

Table 5. Measurement results with use of a mass comparator WAY 1/2Y/KO series and ABBA method

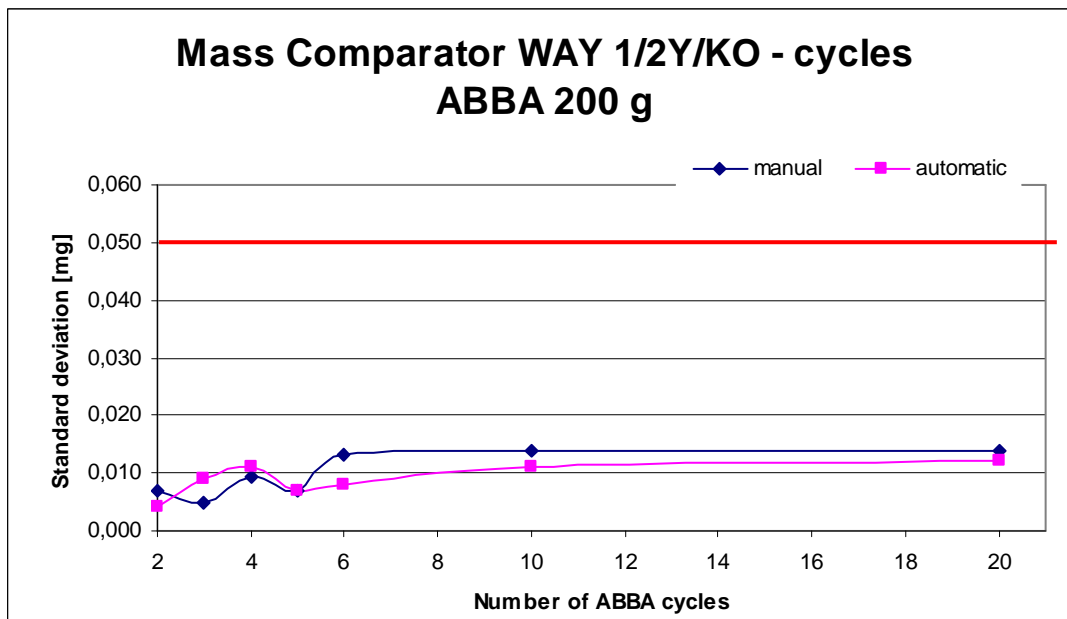

Fig. 16. Chart of standard deviation changes in relation to number of ABBA cycles – for mass 200 g

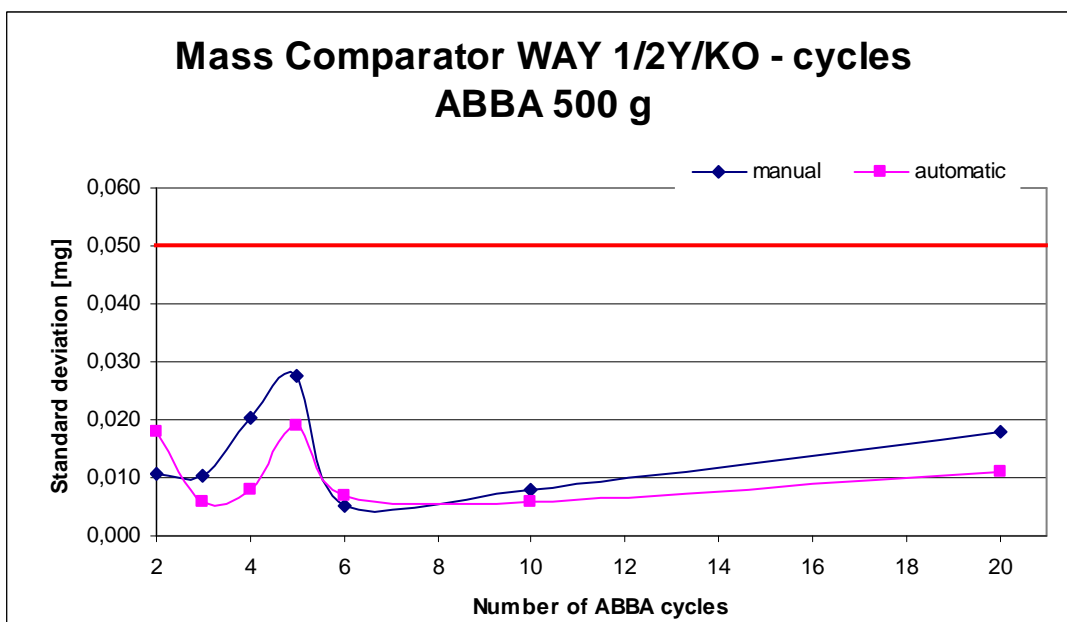

Fig. 17. Chart of standard deviation changes in relation to number of ABBA cycles – for mass 500 g

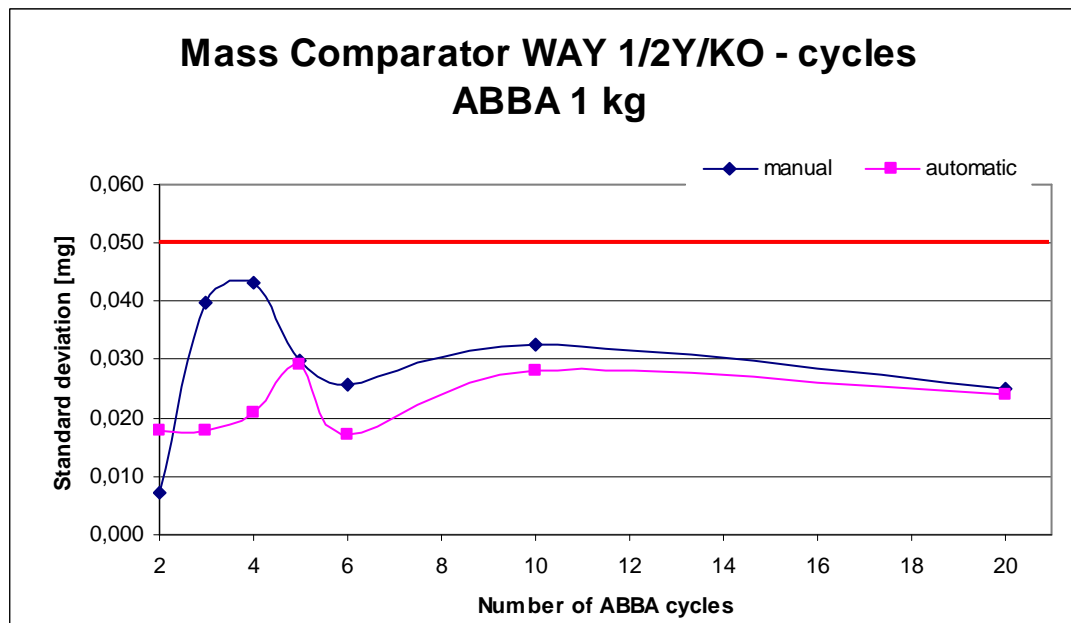

Fig. 18. Chart of standard deviation changes in relation to number of ABBA cycles – for mass 1kg

Analysis of obtained results enables stating, that the standard deviation determined for the ABBA cycles and the mass comparator WAY 1/2Y/KO series, provide similar value of standard deviation both in the automatic and manual mode. The value of standard deviation as declared by the manufacturer of the tested mass comparator is 0,05 mg. The optimal (the lowest) standard deviation in the manual mode for 200 g load has been obtained for 2 and 5 cycles, and in the automatic mode 2 cycles. In case of 500 g load in the manual and automatic mode it is 6 measuring cycles. For the maximum load of 1 kg in the manual mode, the lowest value of standard deviation was obtained in 2 cycles, and in the automatic mode in 6 cycles.

ABA METHOD						
Number of cycles	Load					
	200 g		500 g		1 kg	
	manual	automatic	manual	automatic	manual	automatic
	[mg]	[mg]	[mg]	[mg]	[mg]	[mg]
2	0,000	0,037	0,007	0,004	0,007	0,014
3	0,018	0,013	0,017	0,003	0,033	0,026
4	0,009	0,014	0,024	0,012	0,030	0,029
5	0,012	0,008	0,018	0,014	0,021	0,030
6	0,008	0,029	0,006	0,014	0,030	0,038
7	0,007	0,011	0,021	0,016	0,013	0,038
8	0,011	0,015	0,018	0,021	0,031	0,022
9	0,019	0,009	0,019	0,016	0,028	0,031
10	0,006	0,009	0,015	0,008	0,025	0,031
20	0,012	0,011	0,016	0,013	0,026	0,027
Average	0,01011	0,0156	0,01599	0,0121	0,02441	0,0286
Dispersion	0,019	0,029	0,018	0,018	0,026	0,024

Table 6. Measurement results with use of a mass comparator WAY 1/2Y/KO series and ABA method

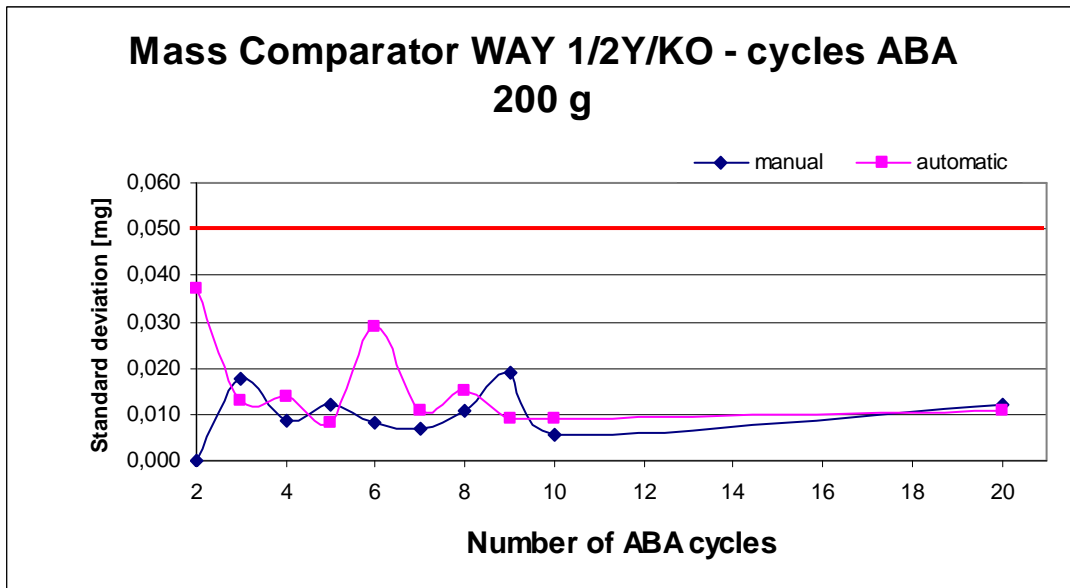

Fig. 19 Chart of standard deviation changes in relation to number of ABA cycles – for mass 200 g

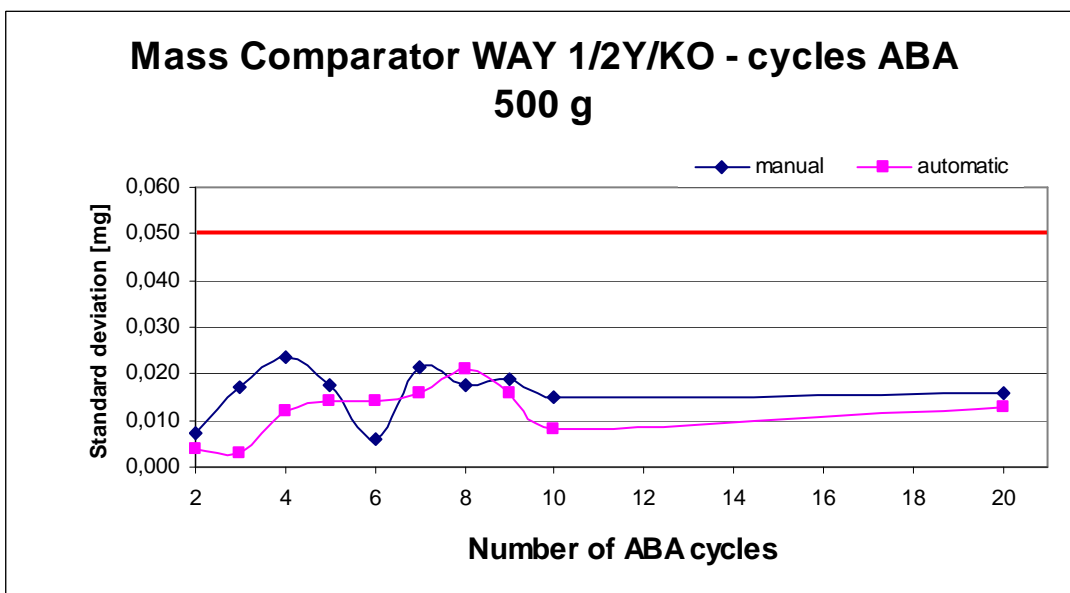

Fig. 20 Chart of standard deviation changes in relation to number of ABA cycles – for mass 500 g

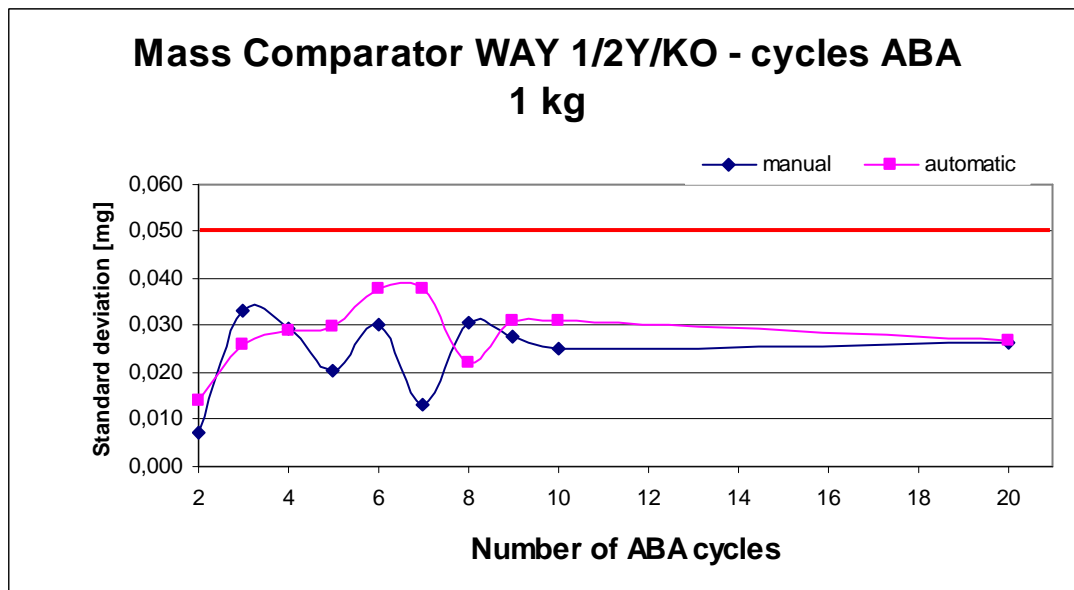

Fig. 21 Chart of standard deviation changes in relation to number of ABA cycles – for mass 1kg

In case of results obtained during testing the mass comparator WAY 1/2Y/KO series using ABA method, it is noticeable, that similarly to the ABBA method, mass comparator's standard deviation in the automatic mode is closely related to standard deviation obtained in manual mode. The lowest standard deviation in the manual mode and for 200 g load is obtained in 10 measuring cycles, and in the automatic mode in 5 cycles. For 500 g load in the manual mode it is 6 measuring cycles, and in the automatic mode - 3 cycles. In case of maximum load of 1 kg in the manual mode the lowest value of standard deviation was obtained for 2 cycles, and in the automatic mode in 8 cycles.

Analysis of carried out calculation for both ABA and ABBA methods enables stating, that in case of tested object the values of standard deviation are comparable.

Mass comparator APP 20/2Y/KO series

ABBA METHOD				
Number of cycles	Load			
	10 kg		20 kg	
	manual	automatic	manual	automatic
	[mg]	[mg]	[mg]	[mg]
2	0	0,2	0,0	0,1
3	0	0,3	0,5	0,2
4	0,8	0,3	0,7	0,3
5	0,5	0,2	0,8	0,3
6	0,4	0,3	0,6	0,3
10	0,7	0,3	1,2	0,3
20	0,7	0,2	1,4	0,3
Average	0,443	0,264	0,743	0,241
Dispersion	0,8	0,07	1,4	0,2

Table 7. Measurement results with use of a mass comparator APP 20/2Y/KO series and ABBA method

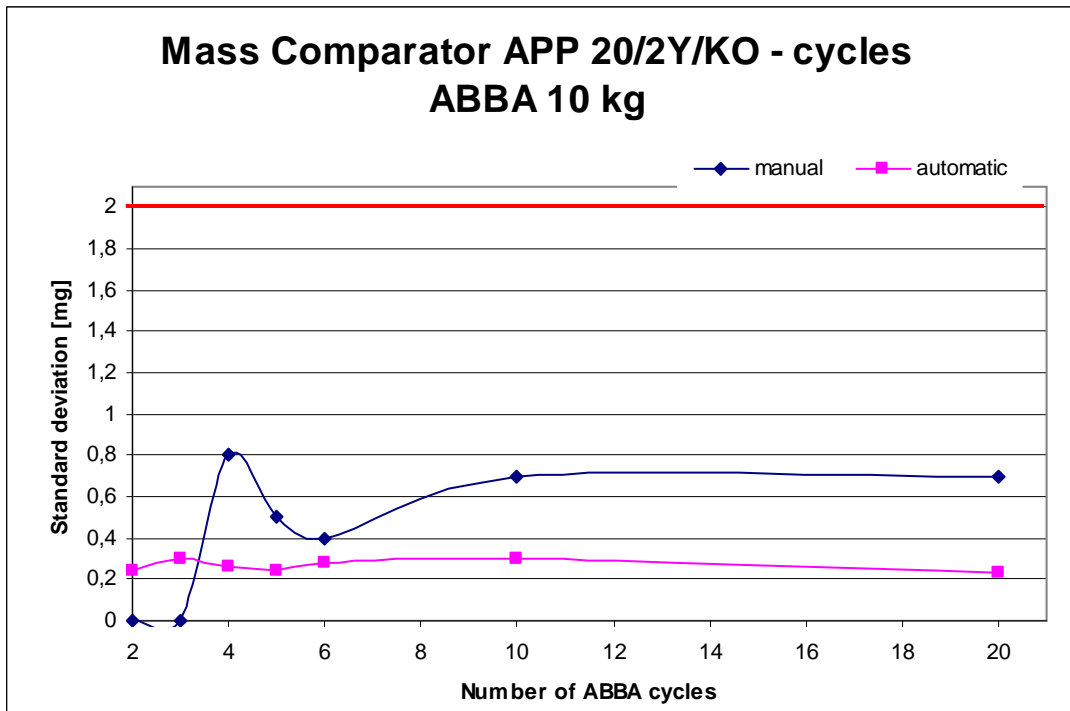

Fig. 22 Chart of standard deviation changes in relation to number of ABBA cycles – for mass 10 k g

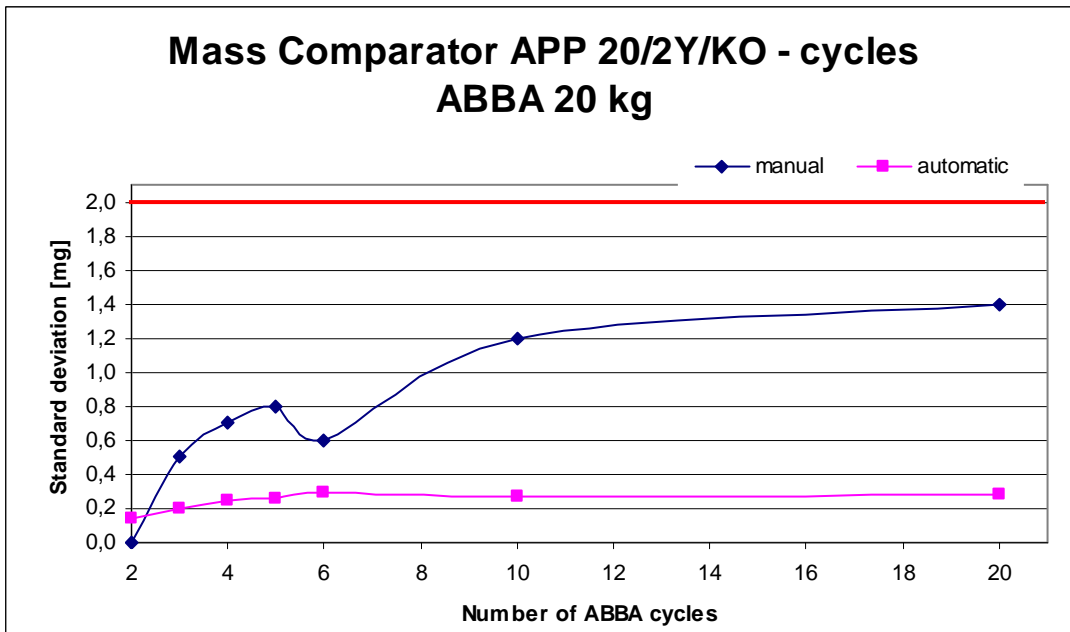

Fig. 23 Chart of standard deviation changes in relation to number of ABBA cycles – for mass 20 k g

Analysis of obtained test results enables noting, that standard deviation determined using the ABBA measuring cycle and the mass comparator APP 20/2Y/KO series is considerably lower (maximally over 4 times in case of 20 kg load and over 3 times in case of 10 kg load) in the automatic mode. The value of standard deviation as declared by the manufacturer of the tested mass comparator is 2 mg. The lowest standard deviation obtained for 10 kg load in the manual mode is for 3 measuring cycles, in the automatic mode practically for any quantity of measuring cycles the data is similar. In case of 20 kg load in the manual mode it is 2 measuring cycles, while in automatic mode it is closely related in case of any quantity of measuring cycles.

ABA METHOD				
Number of cycles	Load			
	10 kg		20 kg	
	manual	automatic	manual	automatic
	[mg]	[mg]	[mg]	[mg]
2	0,7	0,3	0,7	0,3
3	0,5	0,3	0,3	0,3
4	1,1	0,1	1,1	0,2
5	0,9	0,2	0,4	0,3
6	0,6	0,2	0,9	0,3
7	0,8	0,2	1,2	0,3
8	0,4	0,3	0,9	0,2
9	0,6	0,3	1,1	0,3
10	0,7	0,3	0,9	0,3
20	0,8	0,2	1,2	0,3
Average	0,71	0,240	0,87	0,259
Dispersion	0,7	0,2	0,9	0,1

Table 8. Measurement results with use of a mass comparator APP 20/2Y/KO series and ABA method

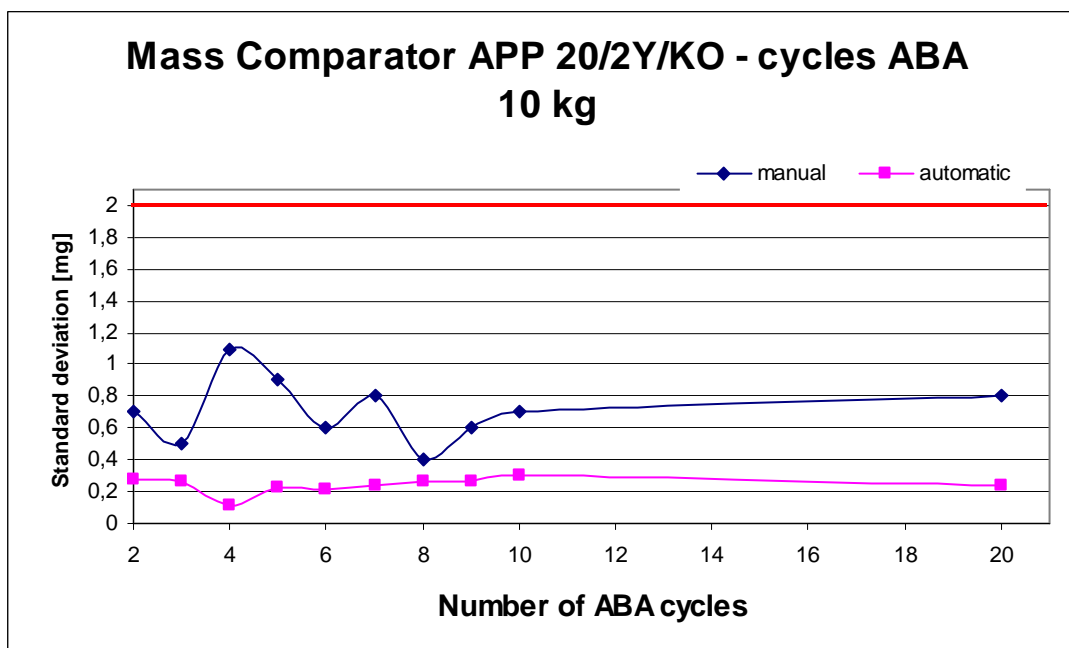

Fig. 24 Chart of standard deviation changes in relation to number of ABA cycles – for mass 10 kg

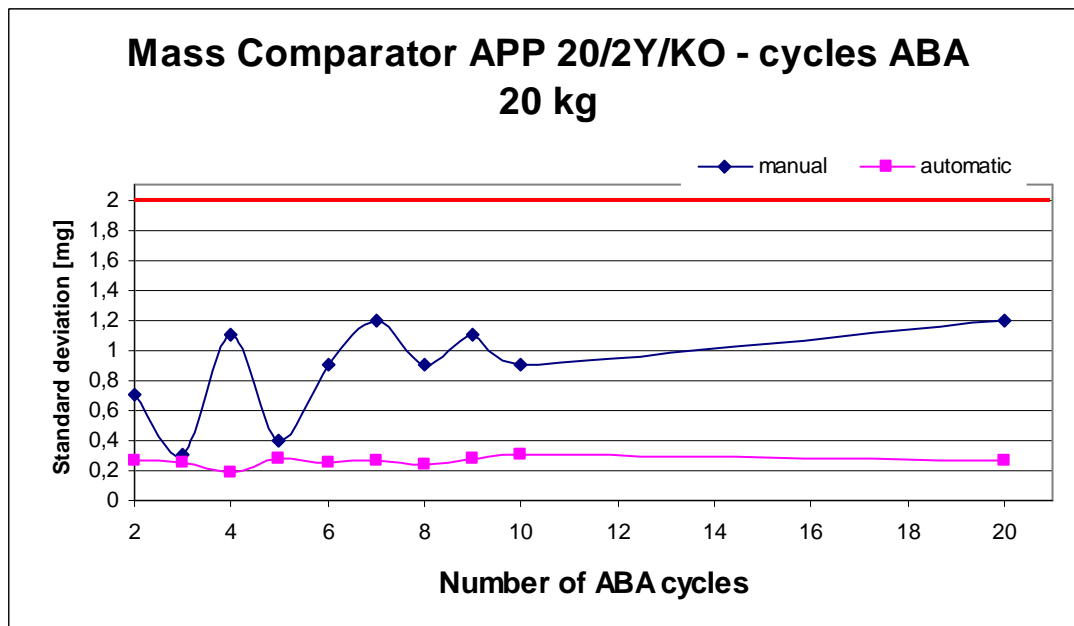

Fig. 25 Chart of standard deviation changes in relation to number of ABA cycles – for mass 20 kg

Analysis of carried out measurements enables stating, that standard deviation determined for ABA measuring cycle of a mass comparator APP 20/2Y/KO series, and for ABBA measuring cycles, is significantly lower in case of automatic mode. The lowest standard deviation in the manual mode and for 10 kg load was obtained in 8 cycles, and in the automatic mode in case of 4 cycles. For 20 kg load, in the manual mode it is 3 cycles, and in the automatic mode it is 4 cycles.

Summarizing data on tested mass comparator, it is noticeable, that automatization of calibration process in case of tested mass comparator has clear effect on the value of repeatability parameter.

4. Uncertainty of measurement in calibration of mass standards and weights

The type and number of cycles, accuracy of the mass comparators or balances used for calibration of mass standards or weights, and the accuracy of reference standards should be selected in a way, that complex expanded uncertainty U at coverage factor $k=2$ during calibration does not exceed 1/3 of maximum permissible errors (Mpe) specified in the Document OIML R111. In accordance with the document of European Cooperation for Accreditation EA-4/02 *Expression of the Uncertainty of Measurement in Calibration*, which is complying with the *International Guide to Express Uncertainty of Measurement*, the procedure of determining uncertainty of measurement on calibration of mass standards begins with noting a measurement equation:

$$m = m_0 + \delta m_1 + \delta m_2 + \delta m_3 + \delta m_4 \quad (8)$$

m_0 – conventional mass of a reference standard

δm_1 – drift value of the reference standard since its last calibration

δm_2 – observed difference in mass of reference standard and tested standard

δm_3 – correction on eccentricity and magnetic effects

δm_4 – air buoyancy correction

The uncertainty equation has to following form:

$$u^2(m) = c_1 u^2(\delta m_1) + c_2 u^2(\delta m_2) + c_3 u^2(\delta m_3) + c_4 u^2(\delta m_4) \quad (9)$$

where c_i is the sensitivity coefficient

Analyzing the means of calculating uncertainty of measurement during calibration of mass standards and weights in accordance with Document OIML R111, enables distinguishing the following components of uncertainty:

type A:

- standard uncertainty of measurement process

type B:

- uncertainty of used reference standard

- uncertainty related to air buoyancy

- uncertainty of used balance (mass comparator)

In the total uncertainty budget of calibration of mass standards and weights, important contribution is related to uncertainties of reference standard, therefore it is particularly important to calibrate using appropriate reference standards with regards to anticipated uncertainty of measurement. The second very important factor is the mass comparator. In these instruments, the element influencing the numerical value of uncertainty of measurement is the repeatability, which is measured by standard deviation.

Table 9 below presents the value of average uncertainties of measurement for each of mass comparators with an assumption, that used reference standards are of accuracy class E_1 , and the repeatability is averaged to all loads (using previously obtained results), and air buoyancy being neglected.

Mass comparator	Load	Expanded uncertainty U		Max uncertainty U for accuracy class E_1 (1/3 <i>mpe</i> R-111)
		manual	automatic	
	[g]	[mg]	[mg]	[mg]
WAY 500/2Y/KO	100	0,015	0,015	0,017
	200	0,021	0,021	0,033
	500	0,044	0,044	0,083
WAY 1/2Y/KO	200	0,022	0,022	0,033
	500	0,044	0,044	0,083
	1 000	0,085	0,085	0,167
APP 20/2Y/KO	10 000	1,48	1,48	1,67
	20 000	2,07	2,07	3,33

Table 9 Uncertainty of measurement in calibration

5. Optimization of laboratory work through automatization of calibration process

In the era when economic factors have noticeable impact also on laboratory operation, an important element is dedicated to labour cost of a laboratory worker carrying out calibration process of mass standards and weights. Analysis of the amount of time required for measurements with application of tested mass comparators and different number of ABBA and ABA measuring cycles enables estimating calibration cost if conducted in automatic or manual mode. The results of average measurement time are demonstrated in Table no. 10.

Method	Number of cycles	Mass comparator					
		WAY 500/2Y/KO		WAY 1/2Y/KO		APP 20/2Y/KO	
		manual	automatic	manual	automatic	manual	automatic
		[min]	[min]	[min]	[min]	[min]	[min]
ABBA	2	8	14	7	13	4	11
	3	10	22	9	19	6	18
	4	12	30	12	25	7	21
	5	15	37	13	32	9	30
	6	17	43	18	38	10	35
	10	27	72	29	63	15	55
	20	60	148	59	130	35	110
ABA	2	7	11	6	11	3	8
	3	9	17	7	15	4	13
	4	10	22	10	18	5	17
	5	12	29	11	24	7	20
	6	13	34	12	30	8	25
	7	17	40	16	33	9	30
	8	18	47	18	39	10	35
	9	20	49	21	42	12	40
	10	22	57	24	48	14	45
	20	45	116	47	101	25	82

Table 10. Average time of mass comparison with division into mass comparators, and depending on applied method and number of measuring cycles

Table 11 below is a demonstration of cost analysis related to calibration of mass standards by a laboratory worker in the manual mode, with taking into consideration assumption on minimum number of measuring cycles for ABBA and ABA methods and with an assumption that cost of 1 man-hour is 20 €.

Method and number of cycles	WAY 500/2Y/KO		WAY 1/2Y/KO		APP 20/2Y/KO	
	Manual	Automatic	Manual	Automatic	Manual	Automatic
ABBA 5 cycles	5,00 €	0,00 € *	4,30 €	0,00 € *	3,00 €	0,00 € *
ABBA 3 cycles	3,30 €	0,00 € *	3,00 €	0,00 € *	2,00 €	0,00 € *
ABA 6 cycles	4,30 €	0,00 € *	4,00 €	0,00 € *	2,70 €	0,00 € *
ABA 4 cycles	3,33 €	0,00 € *	3,30 €	0,00 € *	1,70 €	0,00 € *

Table 11 Calibration cost (*only the cost related to setting of a mass comparator)

CONCLUSIONS

The measurements carried out by RADWAG, employed the most experienced workers, and were subject to a thorough analysis of all negative factors influencing the measurement. In routine work of a calibration laboratory the probability of error occurrence caused by human factor is much higher, therefore automatization of calibration process is the best solution to eliminate this error causing factor.

The carried out analysis of obtained results on repeatability measurements on mass comparators provides the following conclusions:

- Automatization of calibration process and selection of appropriate ABBA or ABA method in case of mass comparators WAY 500/2Y/KO and WAY 1/2Y/KO do not considerable impact on the parameter of repeatability,
- In case of the mass comparator APP 20/2Y/KO series, automatization of calibration process has significant impact on the parameter of repeatability – for 10 kg load the obtained standard deviation value was 0,2 mg in the automatic mode, and 0,7 mg in the manual mode. In case of 20 kg load in the automatic mode the obtained value of standard deviation was 0,3 mg, and in the manual mode 1,4 mg,
- Tested mass comparators featured a four position loading robot which enables simultaneous calibrating of three objects, which is case of high labour cost is very economical
- The four-position loading robot can also be used to compare cumulative mass, which is carried out by advanced laboratories for “unit transferring” process,
- Uncertainty of measurement is not noticeably influenced by a factor related to measuring instrument during calibration of weights, in the tested range and with application of tested mass comparators,
- Calibration of weights from 10 kg to 20 kg requires applying automatization of calibration process to maintain appropriate parameters of repeatability and additionally are used for the sake of operators’ safety – requirements referring to carrying heavy loads by operators, which are generally governed by national laws,
- Automatization of calibration process enables saving operation costs of a calibration laboratory – presently economic factors are extremely important,
- Automatization of calibration process of load ranging between 100 g and 20 kg with application of tested mass comparators and implementation of dedicated software for managing complete operation of a calibration laboratory (e.g. RadCal System designed by RADWAG), enables not only lowering labour cost, but also eliminate the risk of possible error occurrence in calculation process, which may introduce large discrepancies to the measurement traceability.

It is noticeable, that in need to obtain better repeatability (i.e. lower standard deviation) automatization of calibration process can become an indispensable requirement. The influence on uncertainty of measurement during calibration of weights is not observed for the value equal to 1/3 of maximum permissible errors for individual weights, and in accordance with an assumption made in point 5.2 of document OIML R-111. However, if a laboratory aims at achieving better CMC parameters (best measurement capability), then it may become necessary to use automatic mass comparators.

Process automatization enables the designers to enhance the resolution of designed mass comparators with simultaneous decreasing the value of standard deviation, which directly influences the uncertainty of measurement during calibration of weights.

REFERENCES

- [1] PKN-ISO/IEC Guide 99:2010 International Vocabulary of Metrology. Basic and General Concepts and Associated Terms (VIM)
- [2] OIML R 111-1 Edition 2004 Weights of classes E₁, E₂, F₁, F₂, M₁, M₁₋₂, M₂, M₂₋₃ and M₃ Part 1: Metrological and technical requirements
- [3] Guide to the Expression of Uncertainty In Measurements, – Polish edition, Central Office of Measures, Warsaw 1999
- [4] Document EA-4/02: Expression of the Uncertainty of Measurement in Calibration – Polish edition, central Office of Measures, Warsaw 2001
- [5] Piotrowska B., Weights, provisions and comments (Odważniki Przepisy i komentarze), ALFA publishing house, Warsaw 1986
- [6] Arendarski J.: Niepewność pomiaru (Uncertainty of Measurement), PW Publishing House, Warsaw 2006
- [7] New Approach on the Quality of Laboratory Balances, collective work RADWAG, Radom 2011
- [8] Hantz A.: Complete solution in a laboratory calibrating weights, materials for the International Conference on „Traceability of Mass Measurements”, Radom 2011
- [9] Hantz A.: Laboratory Metrology Course P. 2 Measuring Equipment in a Laboratory, ELAMED, Laboratory no. 3-2008