



More information on the website
mirror.radwag.com/us/info,w1,ZYK

WLC 0,6/A1/C/2/IO Precision Balance

WL-217-0039



The drawings, photos and graphics used are for illustrative purposes only.

Functions

 Plus/Minus Control

 Percent Weighing

 Totalizing

 Parts counting

 Internal battery

 Peak hold

 Newton unit measurement

 Under-pan weighing

Datasheet

Metrological parameters	
Maximum capacity [Max]	0,6 kg
Minimum load	0,5 g
Readability [d]	0,01 g
Verification unit [e]	0,1 g
Tare range	-0,6 kg
Repeatability	0,015 g
Linearity	±0,02 g
Stabilization time	3 s
Adjustment	internal (automatic)

Metrological parameters	
OIML Class	II
Physical parameters	
Leveling system	manual
Display	4,3" LCD (backlit)
Weighing pan dimensions	128×128 mm
Packaging dimensions W x D x H	430×270×190 mm
Net weight	3,6 kg
Gross weight	4,5 kg
Construction	
Protection class	IP 43
Communication interface	
Communication interface	2×RS232, USB-A, USB-B, 4 IN / 4 OUT
Electrical parameters	
Power supply	Adapter: 100 – 240V AC 50/60Hz 0,6A; 12V DC 1,2A Balance: 10 – 15VDC 0,6A max
Operation time on batteries	15 h (average time)
Environmental conditions	
Operating temperature	+15 – +30 °C
Relative humidity	10% – 85% RH no condensation



Additional fee for verification



Accessories (Additional Fee)

!Balance Storage Case
 Antivibration tables
 Power Adapters
 RS 232 cables (scale - printer)
 Cigarette lighter receptacle power supply cables
 Under-pan weighing
 RS 232, RS 485 cables

Draft Shield
 RS 232 – Ethernet Converter
 Displays
 Receipt Printer
 Protective cover for balances
 RS 232 – RS 485 Converter

Software (Additional Fee)

- RAD Key [WX-010-0005]
- Scale Editor - EWAG 2.1 [WX-010-0173]

- Alibi Reader PC Software [WX-010-0114]

Device dimensions W x D x H

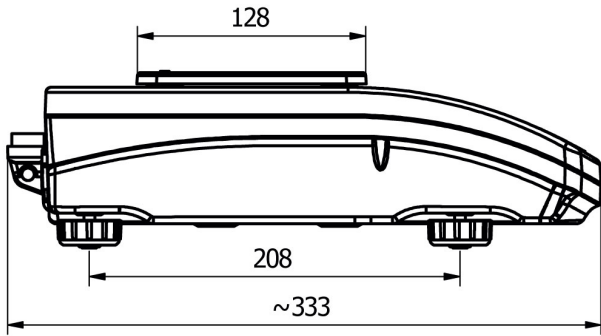

WLC A1

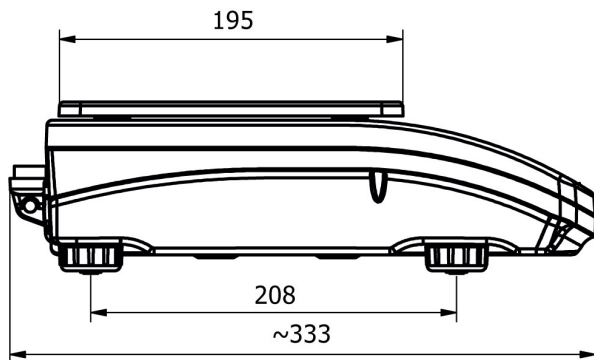
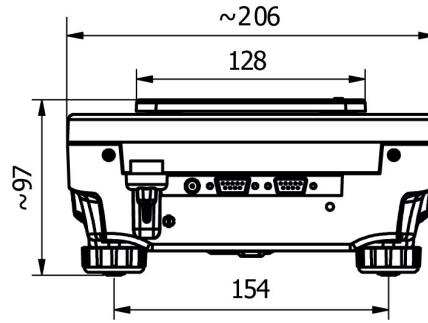

WLC A2

