



More information on the website
mirror.radwag.com/fr/info,w1,ZTJ

Module de balance MAS.1.21

WX-016-0146



The drawings, photos and graphics used are for illustrative purposes only.

Paramètres Techniques

Paramètres métrologiques	
Capacité maximale [Max]	21 g
Capacité minimale [Min]	1 mg
Capacité préliminaire	2,1 g
Précision de lecture [d]	0,01 mg
Étendue de tare	-21 g
Pesée minimale USP	24 mg
Pesée minimale (U=1%, k=2)	2,4 mg
Répétabilité (Max)	0,025 mg
Répétabilité (5% Max)	0,012 mg
Linéarité	±0,06 mg
Temps de stabilisation	6 s
Construction	
Degré de protection	IP 54

Interface de Communication	
Interface de Communication	RS232
Paramètres électriques	
Alimentation	100 – 240 V AC 50/60 Hz
Conditions environnementales	
Température du travail	+10 – +40 °C
Humidité relative d'air	40% – 80%
Paramètres physiques	
Dimension du plateau	ø33 mm
Dimensions d'appareil	289×143×125 mm
Dimensions de colis	650×340×315 mm
Masse nette	4,1 kg
Masse brute	6,1 kg



Accessoires (Additional Fee)

Tables antivibratoires
Câbles RS 232, RS 485
Tables de balance professionnelle

Convertisseur RS 232 – USB
Câbles RS 232, RS 485

Software (Additional Fee)

• RAD Key [WX-010-0005]
• R-LAB [WX-010-0080]

• R Panel [WX-010-0187]
• RADWAG Studio du Développement [WX-010-0104]

Dimensions d'appareil



MAS.1
MAS.1.R



MAS.1

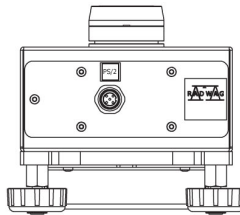

MAS.1.Y

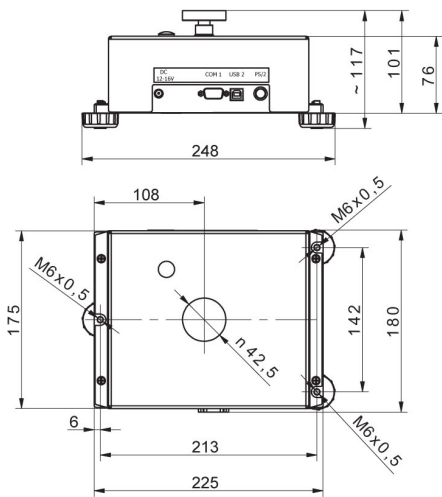

MAS

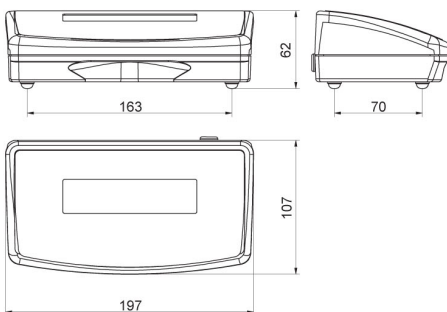

R operator panel



Y operator panel