



More information on the website  
[mirror.radwag.com/es/info,w1,ZTJ](http://mirror.radwag.com/es/info,w1,ZTJ)

## Módulo de pesaje MAS.1.21



The drawings, photos and graphics used are for illustrative purposes only.

### Datos técnicos

Parámetros metrológicos	
Maxima capacidad [Max]	21 g
Minima capacidad	1 mg
Precarga	2,1 g
Legibilidad [d]	0,01 mg
Rango de tara	-21 g
Pesada mínima usp	24 mg
Pesada mínima	2,4 mg
Repetibilidad (Max)	0,025 mg
Repetibilidad (5% Max)	0,012 mg
Linealidad	±0,06 mg
Tiempo de estabilización	6 s
Construcción	
Grado de protección	IP 54

Interface de comunicación	
Conectividad	RS232
Parámetros eléctricos	
Alimentación	100 – 240 V AC 50/60 Hz
Condiciones ambientales	
Temperatura de trabajo	+10 – +40 °C
Humedad relativa de aire	40% – 80%
Parámetros físicos	
Dimensión de platillo	ø33 mm
Dimensiones de aparato	289×143×125 mm
Dimensiones de embalaje	650×340×315 mm
Masa neta	4,1 kg
Masa bruta	6,1 kg



## Accesorios

Mesas antivibratil  
Cables RS 232, RS 485  
Mesas de pesaje profesional

Convertidor RS 232 a USB  
Cables RS 232, RS 485

## Programas

• RAD Key [WX-010-0005]  
• R-LAB [WX-010-0080]

• R Panel [WX-010-0187]  
• RADWAG Development Studio [WX-010-0104]

## Dimensiones de aparato



MAS.1  
MAS.1.R



MAS.1



MAS.1.Y



MAS

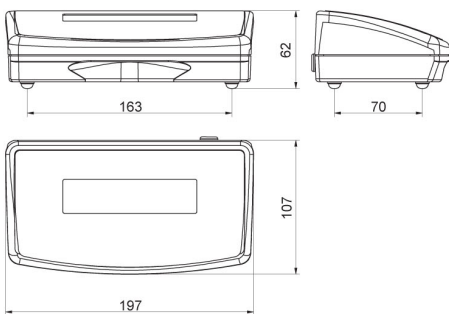

R operator panel



Y operator panel