



More information on the website
mirror.radwag.com/de/info,w1,ZTJ

Wägemodul MAS.1.51

WX-016-0146



The drawings, photos and graphics used are for illustrative purposes only.

Technische Daten

Messtechnische Parameter	
Wägebereich [Max]	21 g
Min. Belastung	1 mg
Vorlast	2,1 g
Zifferschritt [d]	0,01 mg
Tarierbereich	-21 g
Min. Einwaage USP	24 mg
Min. Einwaage (U=1%,k=2)	2,4 mg
Wiederholbarkeit (Max)	0,025 mg
Wiederholbarkeit (5% Max)	0,012 mg
Linearität	±0,06 mg
Stabilisierungszeit	6 s
Konstruktion	
Schutzart	IP 54

Kommunikationsschnittstellen	
Schnittstellen	RS232
Elektrische Parameter	
Stromversorgung	100 – 240 V AC 50/60 Hz
Umgebungsbedingungen	
Umgebungstemperatur	+10 – +40 °C
Relative Luftfeuchtigkeit	40% – 80%
Physikalische Parameter	
Waagschale	ø33 mm
Abmessungen des Geräts	289×143×125 mm
Verpackungsgröße	650×340×315 mm
Nettogewicht	4,1 kg
Bruttogewicht	6,1 kg



Zubehör (Additional Fee)

Antivibrationstische
Kabel RS 232, RS 485
Professionelle Wägestationen

Konverter RS 232 – USB
Kabel RS 232, RS 485

Software (Additional Fee)

- RAD Key [WX-010-0005]
- RLAB [WX-010-0080]

- R Panel [WX-010-0187]
- RADWAG Development Studio [WX-010-0104]

Abmessungen des Geräts



MAS.1
MAS.1.R



MAS.1

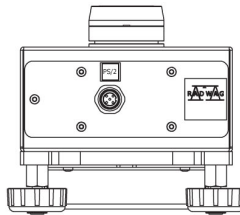

MAS.1.Y

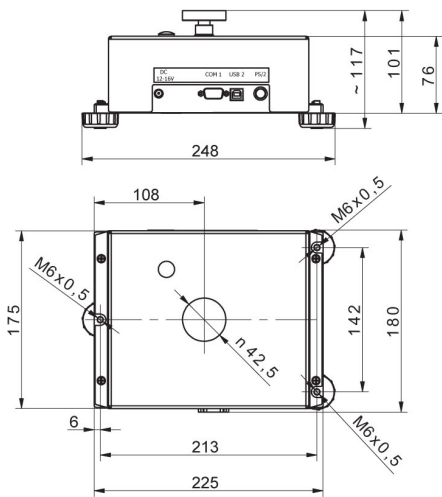

MAS



R operator panel



Y operator panel