



More information on the website  
[mirror.radwag.com/us/info,w1,YXA](http://mirror.radwag.com/us/info,w1,YXA)

# AS 120.R2 PLUS Analytical Balance

WL-104-0191



The drawings, photos and graphics used are for illustrative purposes only.

## Functions



Autotest



Dosing



Percent Weighing



Totalizing



Parts counting



Peak hold



Newton unit measurement



Statistics



Checkweighing



Under-pan weighing



GLP Procedures



Animal weighing



Density determination

## Datasheet

Metrological parameters	
Maximum capacity [Max]	120 g
Minimum load	1 mg
Readability [d]	0,01 mg
Verification unit [e]	1 mg
Tare range	-120 g
Minimum weight (USP)	24 mg

<b>Metrological parameters</b>	
Minimum weight (U=1%, k=2)	2,4 mg
Standard repeatability [Max]	0,03 mg
Standard repeatability [5% Max]	0,012 mg
Permissible repeatability [Max]	0,05 mg
Permissible repeatability [5% Max]	0,02 mg
Linearity	±0,07 mg
Stabilization time	2 s
Adjustment	internal (automatic)
OIML Class	I
<b>Physical parameters</b>	
Leveling system	manual
Display	5,3" LCD (backlit)
Weighing chamber doors	manual
Delivery components	Balance, weighing pan, weighing pan shield, centring ring, bottom cover, power supply, fabric dust cover.
Weighing pan dimensions	ø90 open-work pan + ø85 (option) mm
Packaging dimensions W x D x H	545x455x575 mm
Net weight	7,04 kg
Gross weight	10 kg
<b>Construction</b>	
Protection class	IP 43
<b>Communication interface</b>	
Communication interface	2xRS232 <sup>1</sup> , 2xUSB-A (interchangeable), USB-B, Wi-Fi (option)
<b>Electrical parameters</b>	
Power consumption max.	3 W
<b>Environmental conditions</b>	
Operating temperature	+10 – +40 °C
Relative humidity	40% – 80%

**Repeatability** is expressed as a standard deviation from 10 weighing cycles.

**Stabilization time** depends on the ambient conditions and the dynamics of weighing pan loading; specified for FAST profile.

<sup>1</sup> Barcode scanners, available as weighing instrument accessory, communicate with the instrument via RS232 interface exclusively.

\* Wi-Fi® is a registered trademark of Wi-Fi® Alliance.



Additional fee for verification



## Accessories (Additional Fee)

Antivibration tables  
Power Adapters  
Cigarette lighter receptacle power supply cables  
Density determination KIT

RS 232, RS 485 cables  
Displays  
Protective cover for balances  
Weighing dishes

USB cable (scale - printer)  
Professional Weighing Tables  
Barcode scanners  
Workstation for pipettes calibration  
!Balance Storage Case

Antistatic ionizer  
Receipt Printer  
Under-pan weighing  
RS 232 cables (scale - printer)

## Software (Additional Fee)

- RAD Key [WX-010-0005]
- Alibi Reader PC Software [WX-010-0114]

- R Panel [WX-010-0187]
- RADWAG Development Studio [WX-010-0104]

## Device dimensions W x D x H

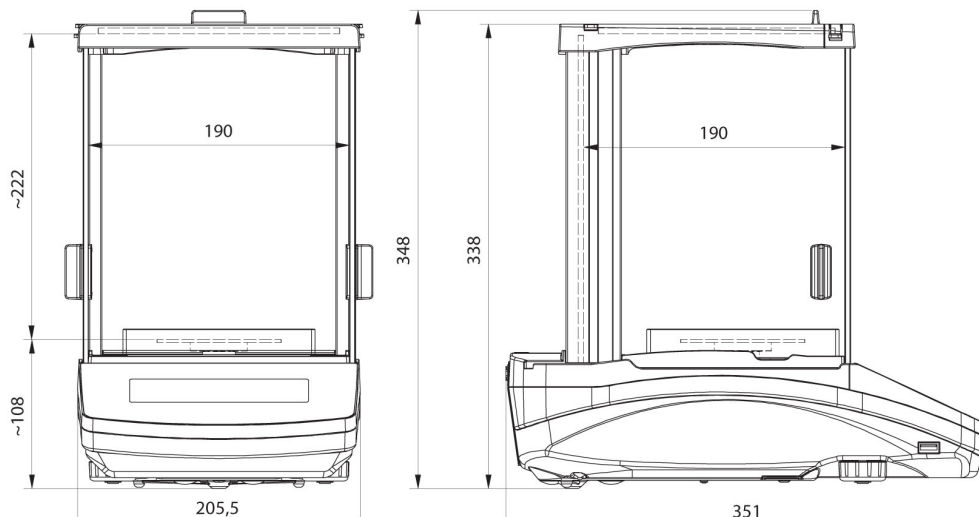

AS R2, d = 0.01 mg

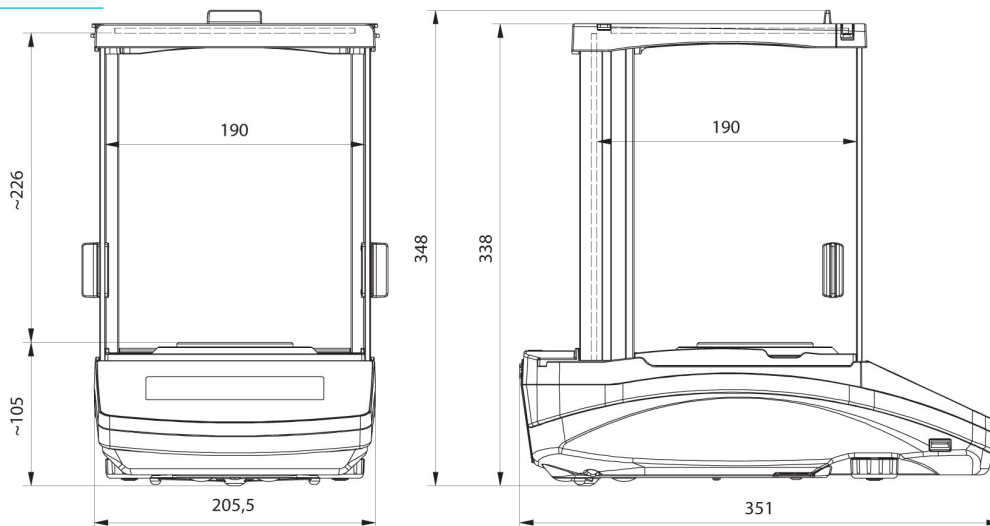

AS R2, AS R1 d = 0.1 mg