



More information on the website
mirror.radwag.com/en/info,w1,YXA

AS 120.R2 PLUS Analytical Balance

WL-104-0191



The drawings, photos and graphics used are for illustrative purposes only.

Functions



Autotest



Dosing



Percent Weighing



Totalizing



Parts counting



Peak hold



Newton unit measurement



Statistics



Checkweighing



Under-pan weighing



GLP Procedures



Animal weighing



Density determination

Datasheet

Metrological parameters	
Maximum capacity [Max]	120 g
Minimum load	1 mg
Readability [d]	0.01 mg
Verification unit [e]	1 mg
Tare range	-120 g
Standard repeatability [5% Max]	0.012 mg

Metrological parameters	
Standard repeatability [Max]	0.03 mg
Standard minimum weight (USP)	24 mg
Standard minimum weight (U=1%, k=2)	2.4 mg
Permissible repeatability [5% Max]	0.02 mg
Permissible repeatability [Max]	0.05 mg
Linearity	±0.07 mg
Stabilization time	2 s
Adjustment	internal (automatic)
OIML Class	I
Physical parameters	
Leveling system	manual
Display	5.3" LCD (backlit)
Weighing chamber doors	manual
Delivery components	Balance, weighing pan, weighing pan shield, centring ring, bottom cover, power supply, fabric dust cover.
Weighing pan dimensions	ø90 open-work pan + ø85 (option) mm
Packaging dimensions W x D x H	545x455x575 mm
Net weight	7.04 kg
Gross weight	10 kg
Construction	
Protection class	IP 43
Communication interface	
Communication interface	2xRS232 ¹ , 2xUSB-A (interchangeable), USB-B, Wi-Fi (option)
Electrical parameters	
Power supply	Adapter: 100 – 240V AC 50/60Hz 0.6A; 12V DC 1.2A Balance: 12 – 15V DC 0.4A max
Power consumption max.	3 W
Environmental conditions	
Operating temperature	+10 – +40 °C
Relative humidity	40% – 80%

Repeatability is expressed as a standard deviation from 10 weighing cycles.

Stabilization time depends on the ambient conditions and the dynamics of weighing pan loading; specified for FAST profile.

¹ Barcode scanners, available as weighing instrument accessory, communicate with the instrument via RS232 interface exclusively.

* Wi-Fi® is a registered trademark of Wi-Fi® Alliance.



Additional fee for verification



Accessories (Additional Fee)

Antivibration Tables
Power Adapters
Cigarette lighter receptacle power supply cables

RS 232, RS 485 cables
Displays
Protective cover for balances

Density determination KIT
USB cable (scale - printer)
Professional Weighing Tables
Barcode scanners
Workstation for Pipettes Calibration

Weighing dishes
Antistatic ionizer
Receipt Printer
Under-pan weighing
RS 232 cables (scale - printer)

Software (Additional Fee)

- RAD Key [WX-010-0005]
- Alibi Reader [WX-010-0114]
- RADWAG Development Studio [WX-010-0104]

- R-Panel [WX-010-0187]
- R-Lab [WX-010-0080]

Device dimensions W x D x H

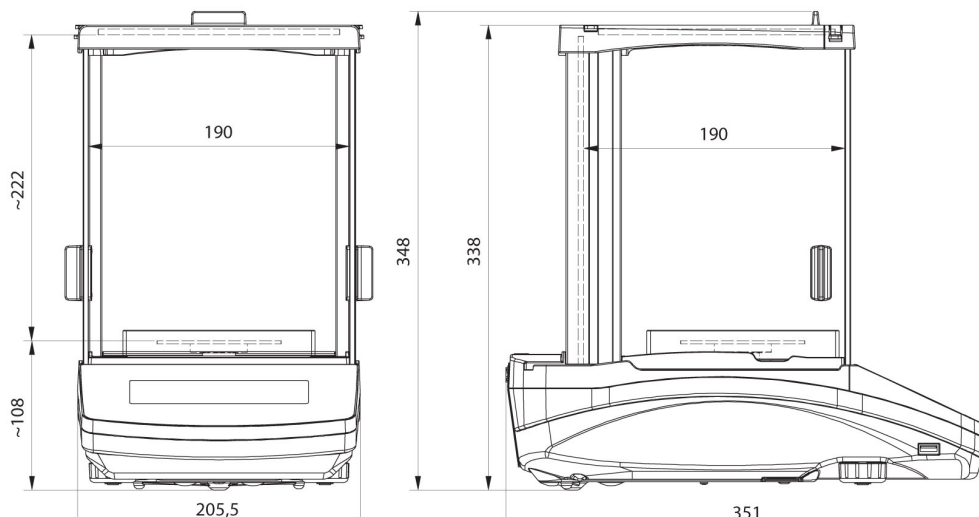

AS R2, d = 0.01 mg

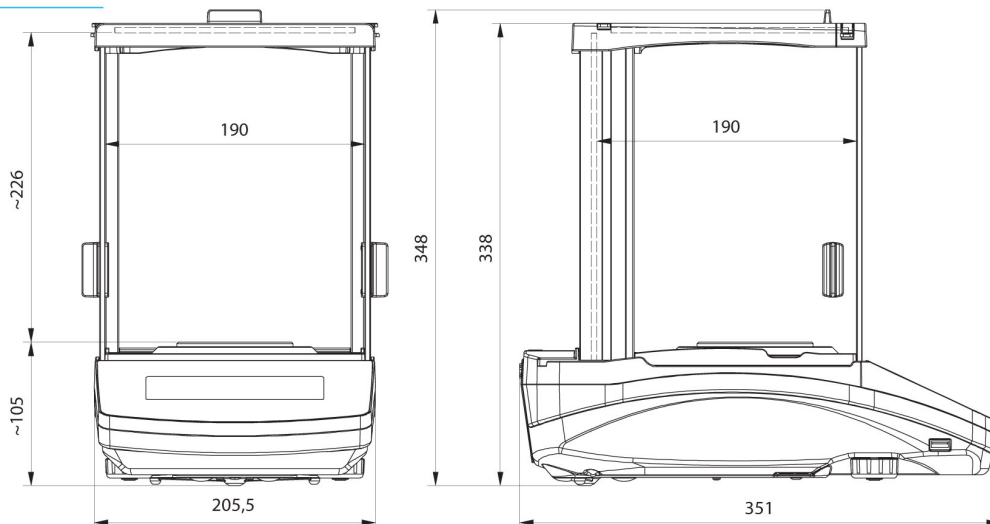

AS R2, AS R1 d = 0.1 mg