



More information on the website
mirror.radwag.com/fr/info,w1,YPC

Balance multifonctionnelle HY10.150.H3/5.K

WP-116-0045



The drawings, photos and graphics used are for illustrative purposes only.

Fonctions

-  Dosing
-  Labelling
-  Plus/Minus Control
-  Percent Weighing
-  Totalizing
-  Parts counting
-  Peak hold
-  Formulation
-  Newton unit measurement
-  Statistics
-  Checkweighing
-  GLP Procedures
-  Animal weighing
-  Differential weighing
-  Replaceable unit
-  Statistical Quality Control
-  ALIBI Memory
-  Transactions

Paramètres Techniques

| Paramètres métrologiques | |
|--------------------------|--------|
| Capacité maximale [Max] | 150 kg |
| Capacité minimale [Min] | 1 kg |
| Précision de lecture [d] | 50 g |

| Paramètres métrologiques | |
|---|--|
| Échelon de légalisation [e] | 50 g |
| Étendue de tare | -150 kg |
| Précision de lecture maximale pour les balances non vérifiées | 5 g |
| Ajustage | externe |
| Classe de précision OIML | III |
| Paramètres physiques | |
| Afficheur | 10,1" graphique couleurs écran tactile |
| Longueur de câble | 2,5 m |
| Dimension du plateau | 400×600 mm |
| Dimensions de colis L x P x H | 490×680×460 mm |
| Masse nette | 16 kg |
| Masse brute | 18 kg |
| Construction | |
| Degré de protection | IP 66 / 67 construction, IP 66 / 67 / 69 terminal |
| Interface de Communication | |
| Interface de Communication | 2×RS232, 2×USB-A, Ethernet, 4 IN / 4 OUT (numériques) |
| Interfaces optionnelles | module Wi-Fi 802.11 b/g/n, module Profibus (DP SLAVE), module RS485, module PROFINET (RJ45), module de sorties analogiques (4-20mA, 0-20mA, 0-10V) , 12IN / 12OUT (IN – 5-24 VDC, OUT – max 30 VDC, 0,5 ADC) |
| Paramètres électriques | |
| Alimentation | 100 – 240 V AC 50/60 Hz |
| Conditions environnementales | |
| Température du travail | -10 – +40 °C |
| Humidité relative d'air | 10% – 85% RH sans condensation |

* Wi-Fi® is a registered trademark of Wi-Fi® Alliance.



Additional fee for verification



Accessoires (Additional Fee)

Sorties de boucle de courant AP2-4
 Câbles RS 232 (balance – imprimante)
 Lecteurs de cartes à transpondeur
 Câbles RS 232 (balance – imprimante ZEBRA)
 Tables antivibratoires
 Câbles de réseau (balance – Ethernet)
 Afficheurs
 Câbles RS 232, RS 485
 Câbles d'Entrées/ de Sorties
 Lecteurs de code-barres

Imprimantes d'étiquettes
 Supports, Statifs, bras-supports
 Claviers, manipulateurs
 Imprimante de tickets de caisse
 Poids de classe F1 - cylindrique à bouton sans cavité d'ajustage, ensembles
 Câble USB (balance – imprimante)
 Modules de plateforme supplémentaires
 Modules complémentaires
 Convertisseur RS 232 – USB
 Plateaux avec les convoyeurs à rouleaux

Software (Additional Fee)

- E2R Pesages [WX-010-0099]
- Audit Trail Reader [WX-010-0186]
- RADWAG Remote Desktop [WX-010-0107]
- Éditeur de Balances 2.1 [WX-010-0173]

- RAD Key [WX-010-0005]
- Éditeur D'étiquettes R02 [WX-010-0094]
- R-LAB [WX-010-0080]
- RADWAG Studio du Développement [WX-010-0104]

Dimensions d'appareil L x P x H

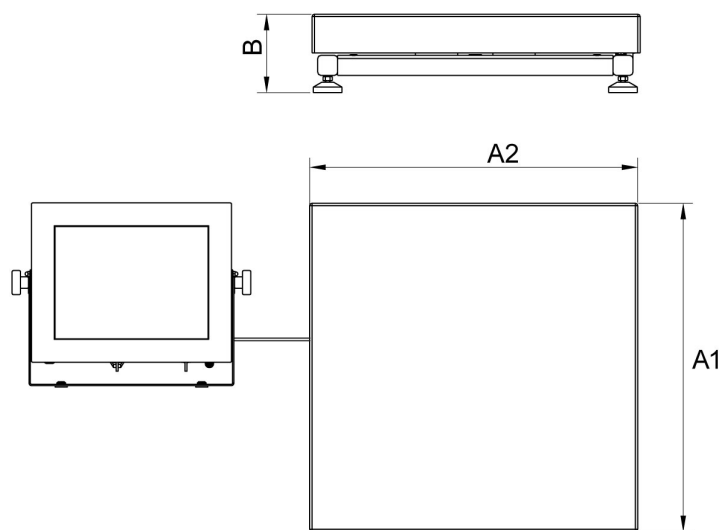

| Scale type | A1 | A2 | B |
|------------|-----|-----|--------|
| HY10 H1.K | 200 | 150 | 85 ±3 |
| HY10 H2.K | 250 | 300 | 103 ±3 |
| HY10 H3.K | 410 | 410 | 98 ±2 |
| HY10 H4.K | 500 | 500 | 155 ±5 |
| HY10 H5.K | 600 | 600 | 155 ±5 |
| HY10 H6.K | 800 | 800 | 135 ±5 |

dimensions in mm

H Platform



PUE HY10