



More information on the website  
[mirror.radwag.com/en/info,w1,WUH](http://mirror.radwag.com/en/info,w1,WUH)

# WAY 500.5Y.KO Mass Comparator

WL-406-0041



The drawings, photos and graphics used are for illustrative purposes only.

## Datasheet

Metrological parameters	
E1 Calibration Range	200 – 500 g
E2 Calibration Range	10 – 500 g
F1 Calibration Range	500 mg – 500 g
F2 Calibration Range	1 mg – 500 g
M1 Calibration Range	1 mg – 500 g
M2 Calibration Range	1 mg – 500 g
Maximum capacity [Max]	520 g
Readability [d]	0.01 mg
Standard repeatability [5% Max]	0.012 mg
Standard repeatability [Max]	0.02 mg
Permissible repeatability	0.035 mg
Eccentricity (tested load)	1d / 1 mm
Electric compensation range	-10 g – +20 g
Stabilization time	30 s
Adjustment	internal

Physical parameters	
Display	10" graphic colour touchscreen
Weighing pan dimensions	ø50 mm
Weighing device dimensions	385×215×525 mm
Controlling device dimensions	249×170×72 mm
Anti-draft chamber dimensions	560×300×665 mm
Packaging dimensions	945×820×1260 mm
Chamber packaging size	820×850×630 mm
Net weight	37.5 kg
Gross weight	57.5 kg
Supplementary weights internal	automatic
Supplementary weights external	30 g, 2×10 g
Communication interface	
Communication interface	2×USB-A, USB-C, RS 232 (COM3), HDMI, Ethernet, Wi-Fi, Hotspot
Environmental conditions	
Operating temperature	+15 – +30 °C
Operating temperature change rate	±0.5 °C / 12 h (±0.3 °C / 4 h)
Relative humidity	40% – 60%
Relative humidity change rate	±3% / 4 h

**Repeatability** is expressed as a standard deviation determined for 6 ABBA cycles. Standard deviation is experimentally determined under ambient conditions for calibration of E1 class mass standards specified in OIML R111 (Table C.1.) document.

\* Wi-Fi® is a registered trademark of Wi-Fi® Alliance.



## Accessories (Additional Fee)

Suspended Self-Centring Weighing Pan for WAY 5Y.KO Manual Mass Comparator	Label Printers
RFID Tags	THBR 2.0 System - Ambient Conditions Monitoring
Antivibration Tables	Receipt Printer
Additional modules	Fingerprint Reader
Protective cover for balances	RS 232, RS 485 cables
Barcode scanners	RS 232 cables (scale - printer)
RS 232, RS 485 cables	

## Software (Additional Fee)

- RAD Key [WX-010-0005]
- RMCS System Network Management of Calibration Process [WX-010-0048]
- RMCS Lite [WX-010-0164]

## Device dimensions



WAY 5.5Y.KO

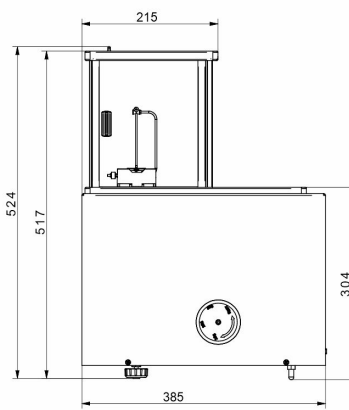

WAY 100.5Y.KO

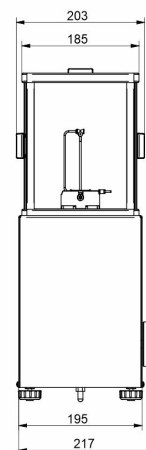

WAY 1200.5Y.KO

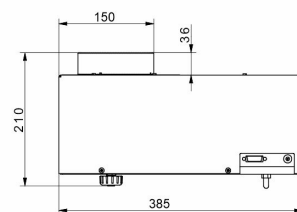

WAY 5100.5Y.KO