



More information on the website
mirror.radwag.com/en/info,w1,WK5

AK-4.5000.5Y Automatic Mass Comparators



The drawings, photos and graphics used are for illustrative purposes only.

Datasheet

| Metrological parameters | |
|---------------------------------|--------------------------------|
| E1 Calibration Range | 1 kg ÷ 5 kg |
| E2 Calibration Range | 1 kg ÷ 5 kg |
| F1 Calibration Range | 1 kg ÷ 5 kg |
| F2 Calibration Range | 1 kg ÷ 5 kg |
| Maximum capacity [Max] | 5.05 kg |
| Readability [d] | 0.01 mg |
| Standard repeatability [5% Max] | 15 µg |
| Standard repeatability [Max] | 20 µg |
| Permissible repeatability | 35 µg |
| Eccentricity (tested load) | 0 mg |
| Electric compensation range | -10 g ÷ +50 g |
| Stabilization time | 30 s |
| Adjustment | external |
| Physical parameters | |
| Display | 10" graphic colour touchscreen |

| Physical parameters | |
|--------------------------------|-----------------|
| Weighing pan dimensions | ø75 mm |
| Weighing device dimensions | 350×405×650 mm |
| Controlling device dimensions | 249×170×72 mm |
| Anti-draft chamber dimensions | 660×470×700 mm |
| Packaging dimensions | 1000×900×685 mm |
| Chamber packaging size | 930×750×1000 mm |
| Net weight | 71 kg |
| Gross weight | 98 kg |
| Supplementary weights internal | half automatic |
| Supplementary weights external | - |

| Communication interface | |
|-------------------------|--|
| Communication interface | 2×USB-A, USB-C, HDMI, Ethernet, Wi-Fi, Hotspot |

| Electrical parameters | |
|-----------------------|-------------------------|
| Power supply | 100 – 240 V AC 50/60 Hz |

| Environmental conditions | |
|-----------------------------------|------------------------|
| Operating temperature | +15 ÷ +30 °C |
| Operating temperature change rate | ±0.5°C/12h (±0.3°C/4h) |
| Relative humidity | 40% ÷ 60% |
| Relative humidity change rate | ±5%/12h (3%/4h) |

Repeatability is expressed as a standard deviation determined for 6 ABBA cycles. Standard deviation is experimentally determined under ambient conditions for calibration of E1 class mass standards specified in OIML R111 (Table C.1.) document.

* Wi-Fi® is a registered trademark of Wi-Fi® Alliance.



Accessories

RFID Tags
 Antivibration Tables
 Additional modules
 Protective cover for balances
 Barcode scanners
 RS 232, RS 485 cables

THBR 2.0 System - Ambient Conditions Monitoring
 Receipt Printer
 Fingerprint Reader
 RS 232, RS 485 cables
 RS 232 cables (scale - printer)

Software

- RAD Key [WX-010-0005]
- RMCS System Network Management of Calibration Process [WX-010-0048]

- RMCS Lite [WX-010-0164]

Device dimensions

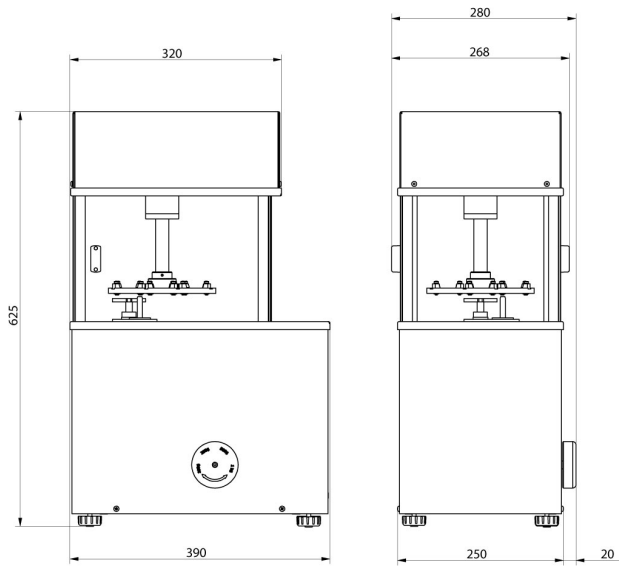

AK-4/100, AK-4/1000,
AK-4/1000.1

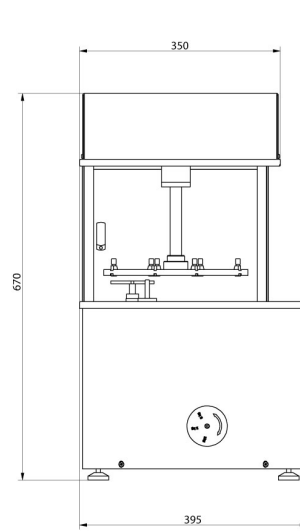

AK-4/2000, AK-4/5000,
AK-4/5000.1

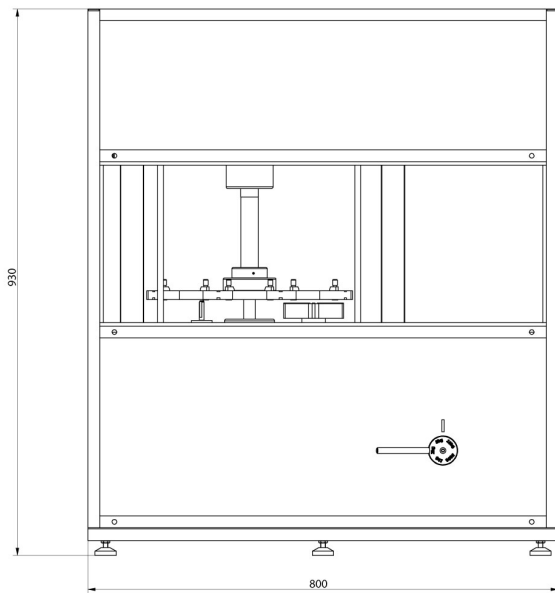
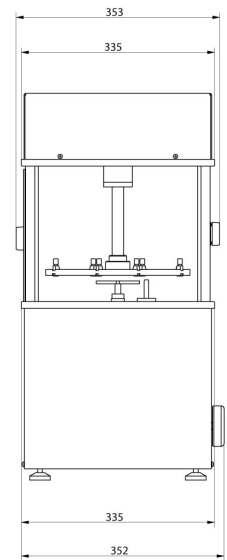

AK-4/10000, AK-4/16000

