



More information on the website
mirror.radwag.com/fr/info,w1,W3Y

PSW/DOUBLE Double station de pesée professionnelle

WX-001-0402



The drawings, photos and graphics used are for illustrative purposes only.

Paramètres Techniques

Paramètres physiques	
Élément du kit	table pour étalonnage, table antivibratoire
Dimensions de colis	1140×820×986 mm
Masse nette	220 kg (table 140 + pierre 80)
Masse brute	252 kg
Longueur	1350 mm
Largeur	750 mm
Hauteur	1100 mm
Nombre de postes	2



Compatible avec (Additional Fee)

Modules MAS1
 Microbalance pour étalonnage des pipettes XA 5Y.M.A.P

Balance analytique AS 5Y
 Balance analytique pour filtres XA 5Y.F

Microbalance pour étalonnage des pipettes MYA 5Y.P
Microbalance pour filtres MYA 5Y.F
Balance analytique AS X7
Balances analytiques AS X2 PLUS
Microbalance XA 5Y.M.A
Modules MAS
Modules MPS

Microbalance MYA 5Y
Balance analytique AS R2 PLUS
Microbalance XA 5Y.M
Comparateur manuel de masse UYA 5Y.KO
Balance analytique AS R1 PLUS
Microbalance pour stents XA 5Y.M.A.S

Dimensions d'appareil

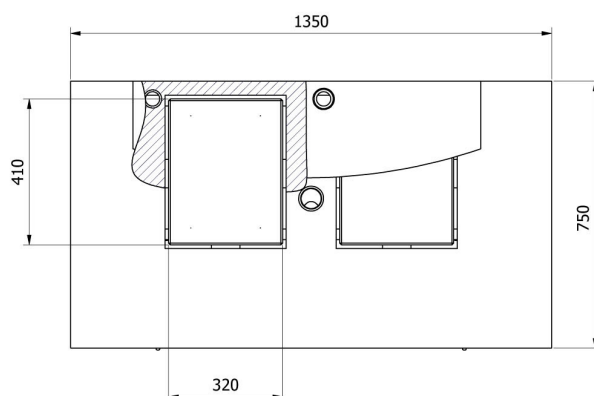
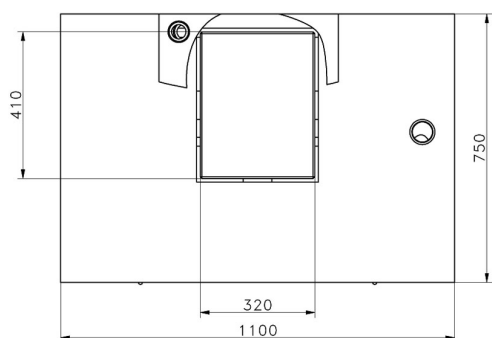
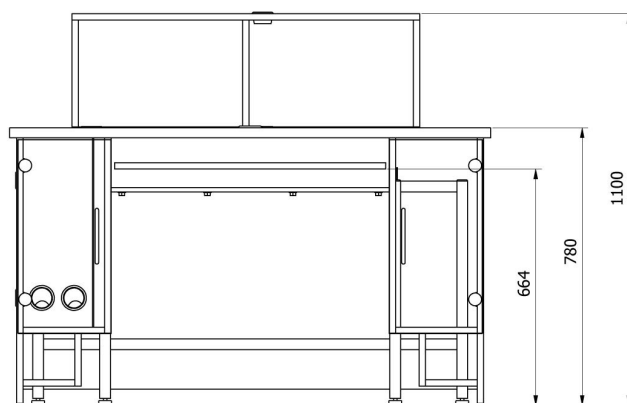
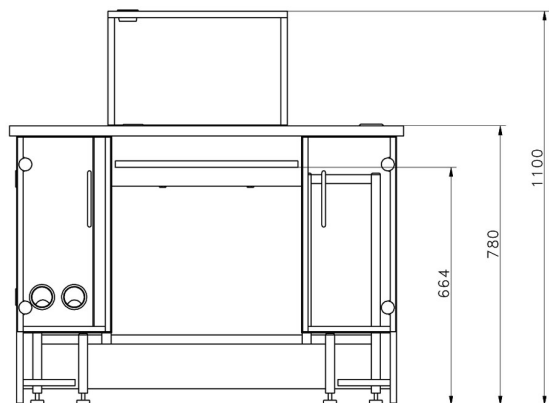

—SDKP

—SDKP DUAL