



More information on the website
mirror.radwag.com/en/info,w1,W3Y

PSW/DUAL Professional Dual Weighing Workstation



The drawings, photos and graphics used are for illustrative purposes only.

Datasheet

Physical parameters	
Delivery components	table for calibration, anti-vibration table
Packaging dimensions	1140×820×986 mm
Net weight	220 kg (table 140 + stone 80)
Gross weight	252 kg
Length	1350 mm
Width	750 mm
Height	1100 mm
Number of workstations	2



Compatible with

MAS1 Modules
 XA 5Y.M.A.P Microbalance for pipettes calibration
 MYA 5Y.P Microbalance for pipettes calibration

AS 5Y Analytical Balance
 XA 5Y.F Analytical Balance for Filters
 MYA 5Y Microbalance

MYA 5Y.F Microbalance for Filters
AS X7 Analytical Balance
AS X2 PLUS Analytical Balances
XA 5Y.M.A Microbalance
MAS Modules
MPS Modules

AS R2 PLUS Analytical Balance
XA 5Y.M Microbalance
UYA 5Y.KO Manual Mass Comparator
AS R1 PLUS Analytical Balance
XA 5Y.M.A.S Microbalance for stents weighing

Device dimensions

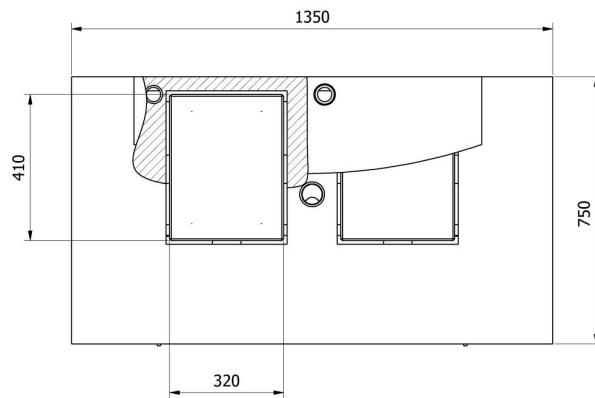
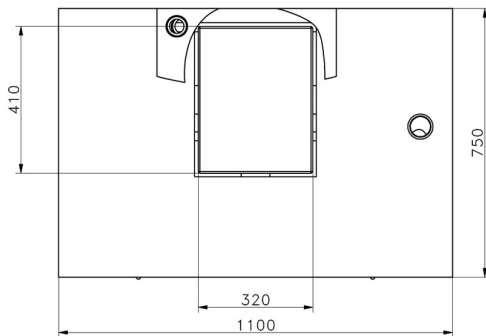
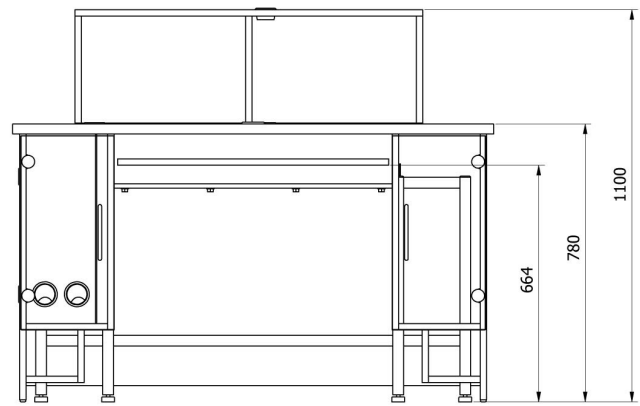
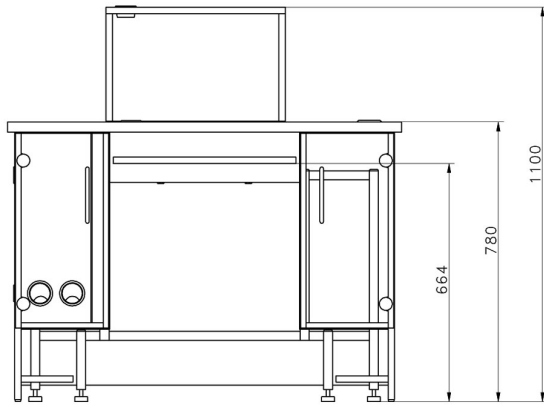

—SDKP

—SDKP DUAL