



More information on the website
mirror.radwag.com/de/info,w1,W3Y

PSW/DUAL Professionelle Doppelwägestation



The drawings, photos and graphics used are for illustrative purposes only.

Technische Daten

Physikalische Parameter	
Lieferumfang	Kalibrierungstabelle, Antivibrationstisch
Verpackungsgröße	1140×820×986 mm
Nettogewicht	220 kg (Tisch 140 + Stein 80)
Bruttogewicht	252 kg
Länge	1350 mm
Breite	750 mm
Höhe	1100 mm
Anzahl der Arbeitsplätze	2



Kompatibel mit

Wägemodule MAS1
 Mikrowaage für Pipettenkalibrierung XA 5Y.M.A.P
 Mikrowaage für Pipettenkalibrierung MYA 5Y.P

Analysenwaage AS 5Y
 Analysenwaage für Filter XA 5Y.F
 Mikrowaage MYA 5Y

Mikrowaage für Filterwägung MYA 5Y.F
Analysenwaage AS X7
Analysenwaagen AS X2 PLUS
Mikrowaage XA 5Y.M.A
Wägemodule MAS
Wägemodule MPS

Analysenwaage AS R2 PLUS
Mikrowaage XA 5Y.M
Manueller Massekomparator UYA 5Y.KO
Analysenwaage AS R1 PLUS
Mikrowaage für Stentwägung XA 5Y.M.A.S

Abmessungen des Geräts

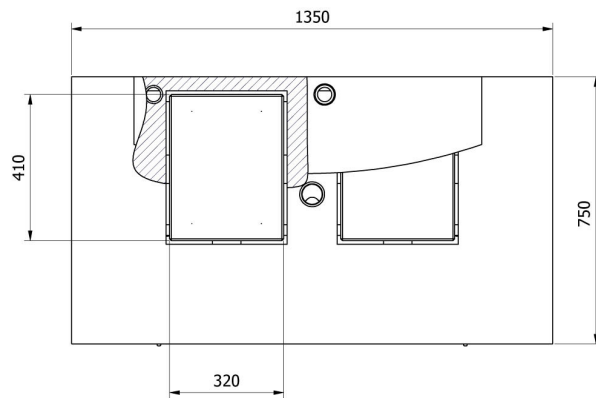
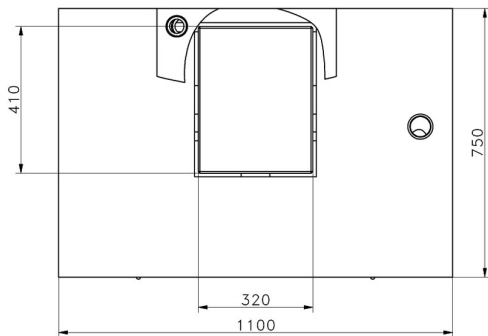
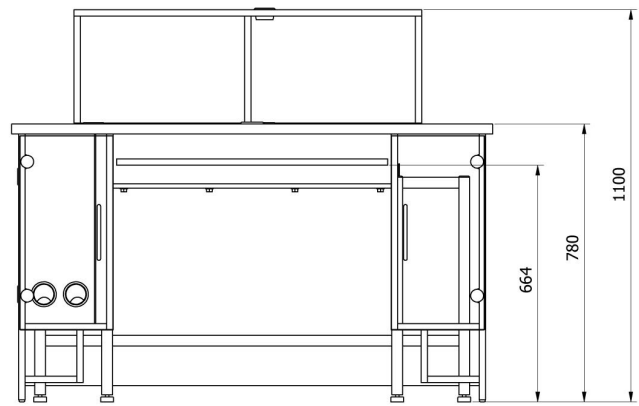
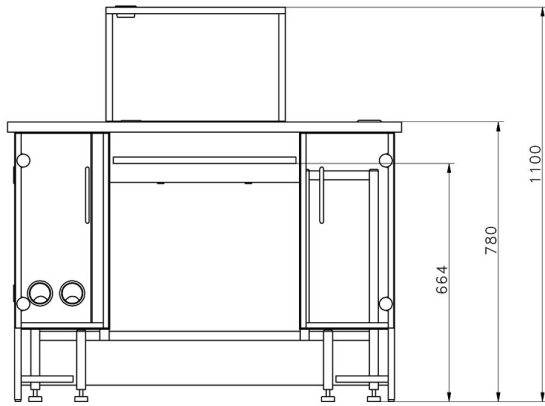

—SDKP

—SDKP DUAL