



More information on the website
mirror.radwag.com/en/info,w1,UVT

WLC 2/A2/C/2 Precision Balance

WL-217-0015



The drawings, photos and graphics used are for illustrative purposes only.

Functions

 Plus/Minus Control

 Percent Weighing

 Totalizing

 Parts counting

 Internal battery

 Peak hold

 Newton unit measurement

 Under-pan weighing

Datasheet

Metrological parameters

Maximum capacity [Max]	2 kg
Readability [d]	0.01 g
Verification unit [e]	-
Tare range	-2 kg
Repeatability	0.015 g
Linearity	±0.03 g
Stabilization time	3 s
Adjustment	internal (automatic)

Physical parameters	
Leveling system	manual
Display	4.3" LCD (backlit)
Weighing pan dimensions	195×195 mm
Packaging dimensions W x D x H	430×270×190 mm
Net weight	3.29 kg
Gross weight	4.5 kg
Construction	
Protection class	IP 43
Communication interface	
Communication interface	2×RS232, USB-A, USB-B
Electrical parameters	
Power supply	Adapter: 100 – 240V AC 50/60Hz 0.6A; 12V DC 1.2A Balance: 10 – 15VDC 0.6A max
Operation time on batteries	15 h (average time)
Environmental conditions	
Operating temperature	+15 – +30 °C
Relative humidity	10% – 85% RH no condensation

Repeatability is expressed as a standard deviation from 10 weighing cycles.

Stabilization time depends on the ambient conditions and the dynamics of weighing pan loading; specified for FAST profile.



Accessories (Additional Fee)

Balance Storage Case
 Antivibration Tables
 Power Adapters
 RS 232 cables (scale - printer)
 Cigarette lighter receptacle power supply cables
 Under-pan weighing
 RS 232, RS 485 cables

Density determination KIT
 RS 232 – Ethernet Converter
 Displays
 Receipt Printer
 Protective cover for balances
 RS 232 – RS 485 Converter

Software (Additional Fee)

- RAD Key [WX-010-0005]
- R-Lab [WX-010-0080]

- Alibi Reader [WX-010-0114]
- Scale Editor 2.1 [WX-010-0173]

Device dimensions W x D x H



WLC A1

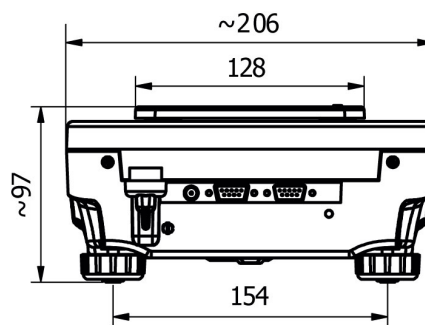

WLC A2

