



More information on the website  
[mirror.radwag.com/tr/info,w1,TS4](http://mirror.radwag.com/tr/info,w1,TS4)

## C10 3000kg kantar için rampa



The drawings, photos and graphics used are for illustrative purposes only.

### Teknik Veriler

Metrolojik parametreler	
Ticari amaçla kullanılmayan terazi için maksimum hassasiyet	200 g
Konstrüksiyon	
Malzeme	toz kaplı çelik
Fiziksel parametreler	
Platform size	1500×1460 mm



### İle uyumlu

HX7.4C Çok Fonksiyonlu Platform Kantar  
C315.4 platform kantarları

H315 4C platform kantarları

# Cihaz boyutları

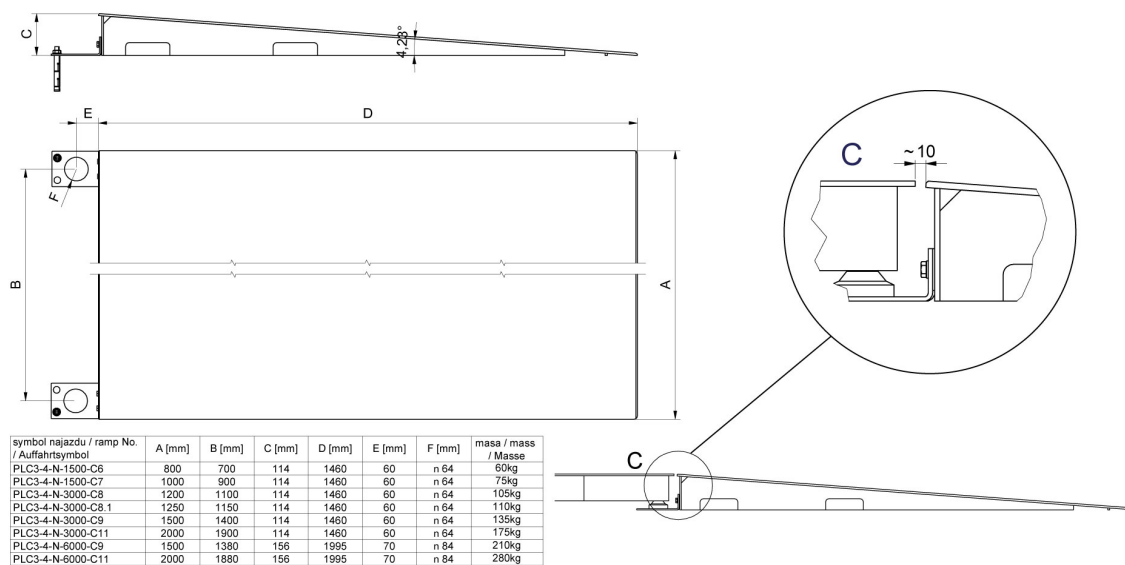

## Ramps made of powder-coated steel

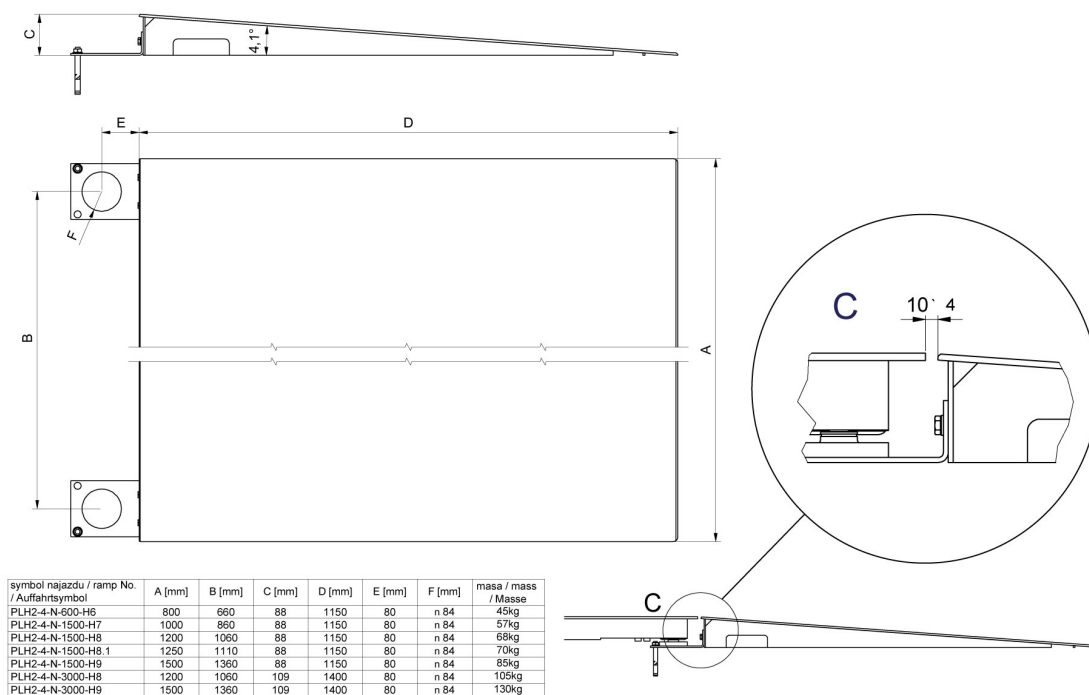

## Ramps made of stainless steel