



More information on the website  
[mirror.radwag.com/de/info,w1,TS4](https://mirror.radwag.com/de/info,w1,TS4)

# Rampe für C10 3000kg Wägebrücken



The drawings, photos and graphics used are for illustrative purposes only.

## Technische Daten

Messtechnische Parameter	
Max Ablesbarkeit [d] bei nicht geeichter Waage	200 g
Konstruktion	
Material	pulverbeschichteter Stahl
Physikalische Parameter	
Abmessungen Wägebrücke	1500×1460 mm



## Kompatibel mit

Multifunktions- Plattformwaage HX7.4C  
 Plattformwaagen C315.4

Plattformwaage  
 H315 4C

# Abmessungen des Geräts

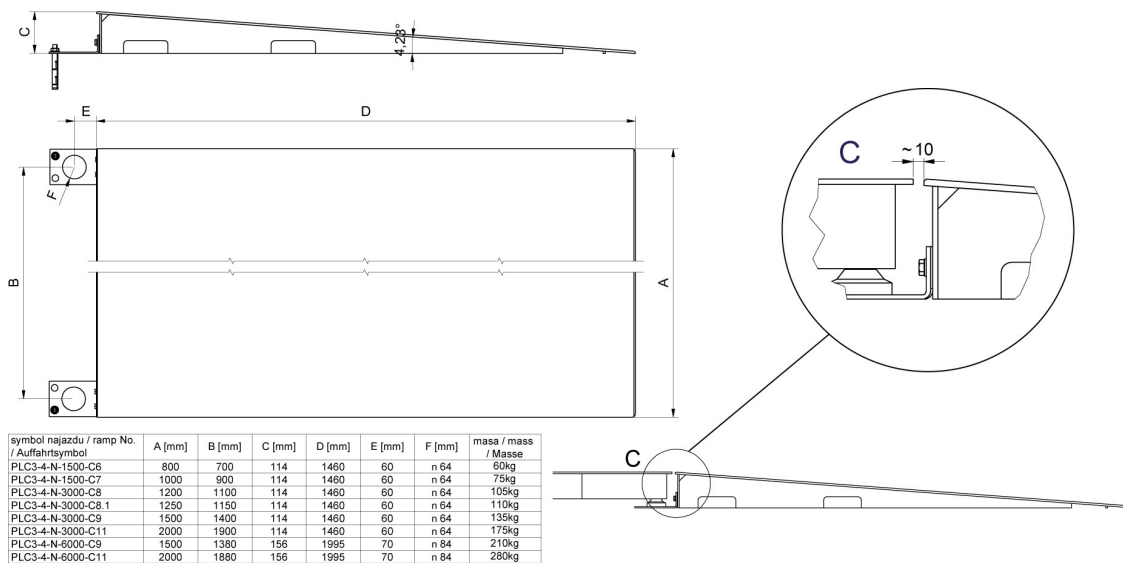

Ramps made of powder-coated steel

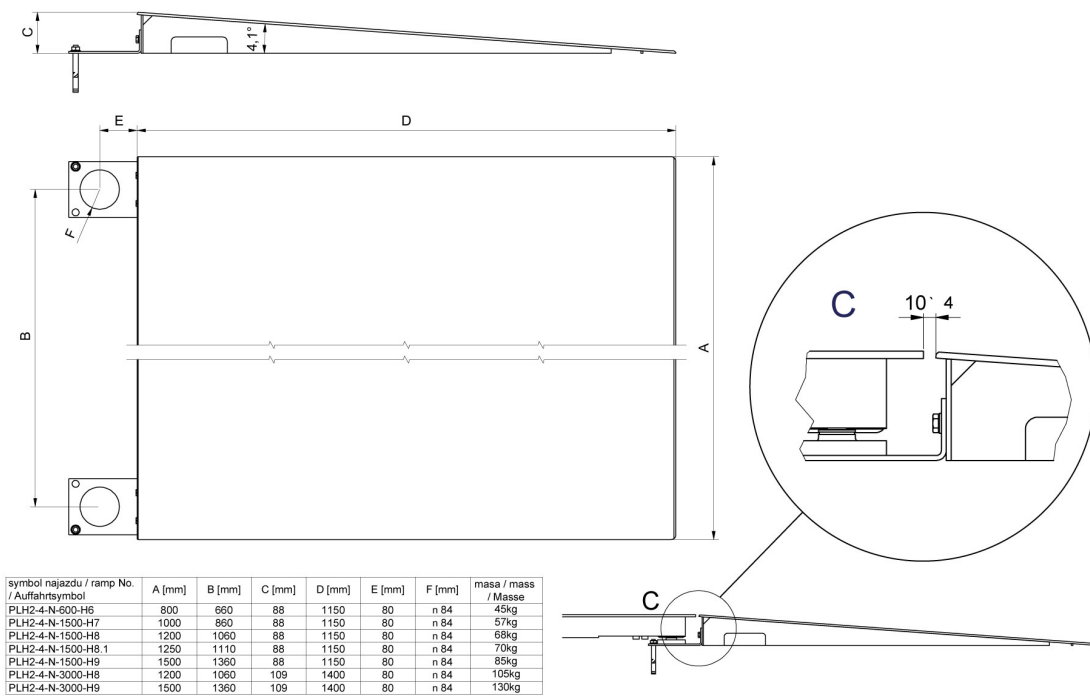

Ramps made of stainless steel