

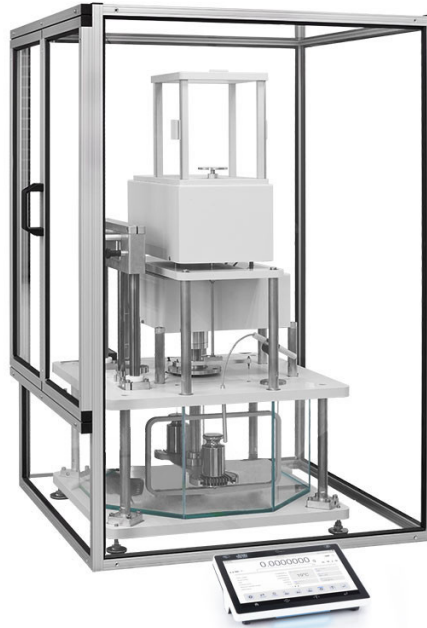

More information on the website
mirror.radwag.com/en/info,w1,T4L

AGV-2 20.5Y Automatic Comparator



The drawings, photos and graphics used are for illustrative purposes only.

Datasheet

Metrological parameters	
E1 Calibration Range	1 – 20 kg
E2 Calibration Range	1 – 20 kg
F1 Calibration Range	1 – 20 kg
F2 Calibration Range	1 – 20 kg
Maximum capacity [Max]	26.1 kg
Readability [d]	1 mg
Standard repeatability [5% Max]	2 mg
Standard repeatability [Max]	3 mg
Permissible repeatability	6 mg
Electric compensation range	100 g – +26.1 kg
Stabilization time	30 s
Adjustment	external
Physical parameters	
Display	10" graphic colour touchscreen
Weighing pan dimensions	ø220 mm self centering

Physical parameters	
Object diameters	25 – 145 mm
Magazine positions	automatic 2 positions
Electrical parameters	
Power supply	100 – 240 V AC 50/60 Hz
Environmental conditions	
Operating temperature	+15 – +30 °C
Storage temperature	-20 – +50 °C
Operating temperature change rate	±0.5 °C / 12 h (±0.3 °C / 4 h)
Relative humidity	40% – 60%
Relative humidity change rate	±5% / 12 h (3% / 4 h)

Repeatability is expressed as a standard deviation determined for 6 ABBA cycles.



Accessories

RFID Tags
 Additional modules
 Protective cover for balances
 Barcode scanners
 RS 232, RS 485 cables

THBR 2.0 System - Ambient Conditions Monitoring
 Receipt Printer
 Fingerprint Reader
 RS 232, RS 485 cables
 RS 232 cables (scale - printer)

Software

• RMCS Lite [WX-010-0164]

• RMCS System Network Management of Calibration Process [WX-010-0048]

Device dimensions



AGV-8/1000



AGV-8/1000
Anti-draft chamber ver.1

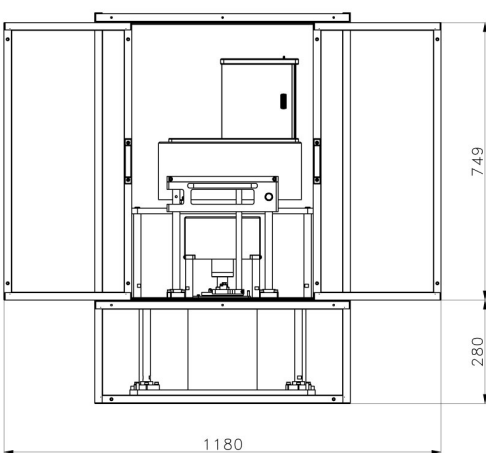

AGV-8/1000
Anti-draft chamber ver.2