



More information on the website
mirror.radwag.com/it/info,w1,T45

Sistema di pesatura su rotaia H315.2K.300/600H

WP-238-1002



The drawings, photos and graphics used are for illustrative purposes only.

Funzioni

 Plus/Minus Control

 Percent Weighing

 Totalizing

 Parts counting

 Internal battery

 Peak hold

 Newton unit measurement

 Animal weighing

Specifiche

Parametri metrologici	
Portata massima [Max]	300 / 600 kg
Portata minima [Min]	2 kg
Divisione [d]	0,1 / 0,2 kg
Intervallo di verifica della bilancia [e]	0,1 / 0,2 kg
Campo di tara	-600 kg
Classe OIML	III
Parametri fisici	
Display	4,3" LCD (backlit)

Parametri fisici	
Ampiezza della linea di controllo	L= 800 mm (min. 200 mm)
Costruzione	
Punteggio IP	IP 66 / 69 construction, IP 66 / 67 / 69 terminal
Costruzione	Stainless steel AISI304
Interfaccia di comunicazione	
Interfaccia	RS232, USB
Interfacce opzionali	RS232 or RS485 or 4IN/4OUT or Ethernet or analog output 4-20 mA
Parametri elettrici	
Alimentatore	100 – 240 V AC 50/60 Hz
Alimentatore opzionale	internal rechargeable battery
Tempo operativo delle batterie	max 7h
Environmental conditions	
Ambiente di lavoro	-10 – +40 °C
Umidità relativa	10% – 85% RH no condensation



Additional fee for verification



Accessori (Additional Fee)

AP2-4 Modulo di conversione analogica
 Cavo seriale RS 232 (connessione bilance - Stampanti)
 Display
 Cavi di rete (connessione bilance - Ethernet)
 Cavo seriale RS 232, RS 485
 Alimentatore

Convertitore RS 232 – Ethernet
 USB adapter
 Stampanti di ricevuta
 Cavo USB (connessione bilance - stampanti)
 Supporto, set di montaggio a muro e braccetti di montaggio
 Convertitore RS 232 – USB

Software (Additional Fee)

- RAD Key [WX-010-0005]
- Editore per sistemi di pesatura 2.1 [WX-010-0173]

- R-LAB [WX-010-0080]

Device dimensions L x P x A

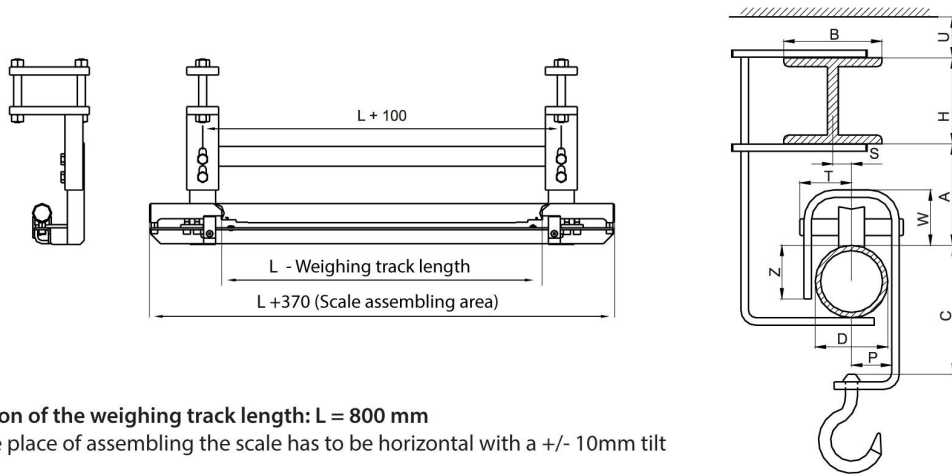

CAUTION

- Standard version of the weighing track length: $L = 800 \text{ mm}$
- The truck in the place of assembling the scale has to be horizontal with a $\pm 10 \text{ mm}$ tilt limit
- The dimensions bearing the letters are to be agreed with contractor manufacturing Z dimension; the dimensions can be omitted if the following relation is fulfilled: $Z \leq 80\% D$

Dimensions of an overhead track scale with a shaft of $\varnothing 60$ (standard version)

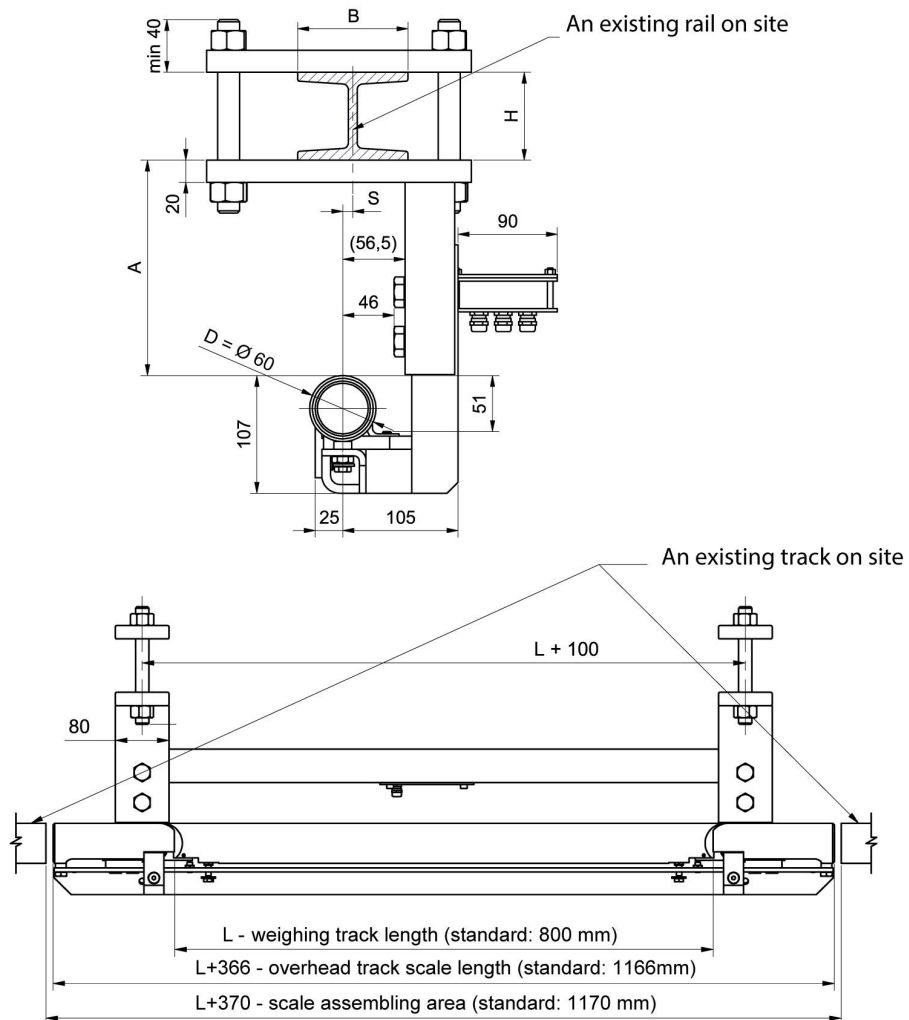

Minimum track clearance: $A = 90 \text{ mm}$.
 Weighing track length: $200 \leq L \leq 800 \text{ mm}$. As a standard: $L=800 \text{ mm}$.
 Maximum capacity: 600 kg .