



# Báscula de carriles H315.2K.300/600H

WP-238-1002



The drawings, photos and graphics used are for illustrative purposes only.

## Funciones

 Control más/menos

 Desviaciones porcentuales

 Resumiendo pesajes

 Contar piezas

 Batería interna

 Cierre de la indicación máxima

 Medición en Newtons

 Pesar animales

## Datos técnicos

### Parámetros metrológicos

Maxima capacidad [Max]	300 / 600 kg
Minima capacidad	2 kg
Legibilidad [d]	0,1 / 0,2 kg
División de legalización [e]	0,1 / 0,2 kg
Rango de tara	-600 kg
Clase OIML	III

### Parámetros físicos

Pantalla	4,3" LCD (con retroiluminación)
Longitud de la trayectoria de medición	L= 800 mm (min. 200 mm)

<b>Construcción</b>	
Grado de protección	IP 66 / 69 construcción, IP 66 / 67 / 69 medidor
Construcción	Acero inoxidable AISI304
<b>Interface de comunicación</b>	
Conectividad	RS232, USB
Interfaces opcionales	RS232 o RS485 o 4IN/4OUT o Ethernet o entradas analógica 4-20 mA
<b>Parámetros electricos</b>	
Alimentacion	100 – 240 V AC 50/60 Hz
Corriente de alimentación adicional	batería interna
Horas de trabajo con baterias	max 7h
<b>Condiciones ambientales</b>	
Temperatura de trabajo	-10 – +40 °C
Humedad relativa de aire	10% – 85% RH sin condensación



Additional fee for verification



## Accesorios (Additional Fee)

Salidas del bucle de corriente AP2-4  
 Cables RS 232 (Bascula a Impresora)  
 Pantallas  
 Cables de corriente (Bascula a Ethernet)  
 Cables RS 232, RS 485  
 Adaptadores de corriente

Convertidor RS 232 a Ethernet  
 Adaptadores USB  
 Impresoras de recibos  
 Cable USB (Bascula a Impresora)  
 Soportes, brazos  
 Convertidor RS 232 a USB

## Programas (Additional Fee)

- RAD Key [WX-010-0005]
- Editor de Balanzas 2.1 [WX-010-0173]

- R-LAB [WX-010-0080]

# Dimensiones de aparato An x Pr x Al

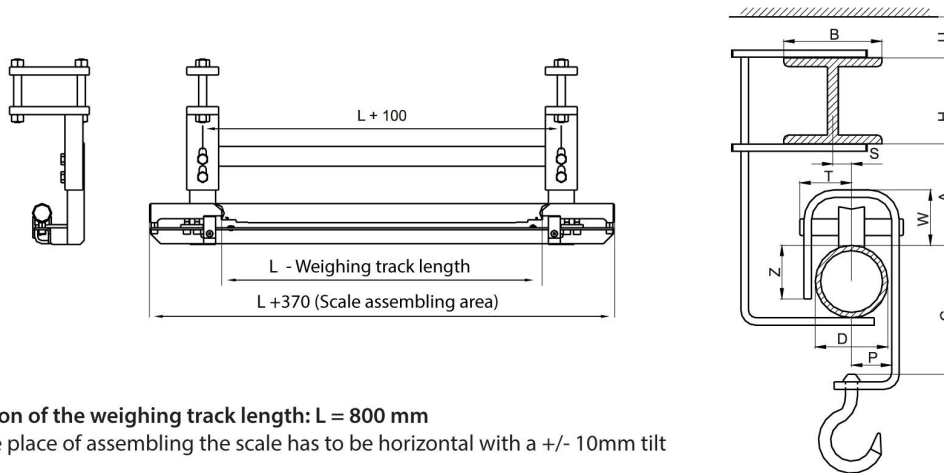

## CAUTION

- Standard version of the weighing track length:  $L = 800$  mm
- The truck in the place of assembling the scale has to be horizontal with a  $\pm 10$ mm tilt limit
- The dimensions bearing the letters are to be agreed with contractor manufacturing Z dimension; the dimensions can be omitted if the following relation is fulfilled:  $Z \leq 80\% D$

Dimensions of an overhead track scale with a shaft of  $\varnothing 60$  (standard version)



Minimum track clearance:  $A = 90$  mm.

Weighing track length:  $200 \leq L \leq 800$  mm. As a standard:  $L=800$  mm.

Maximum capacity: 600 kg.