



More information on the website
mirror.radwag.com/de/info,w1,T45

Rohrbahnwaage H315.2K.300/600H

WP-238-1002



The drawings, photos and graphics used are for illustrative purposes only.

Funktionen



Plus/Minus Control



Percent Weighing



Totalizing



Parts counting



Internal battery



Peak hold



Newton unit measurement



Animal weighing

Technische Daten

Messtechnische Parameter

Wägebereich [Max]	300 / 600 kg
Min. Belastung	2 kg
Ablesbarkeit [d]	0,1 / 0,2 kg
Eichwert [e]	0,1 / 0,2 kg
Tarierbereich	-600 kg
OIML-Klasse	III

Physikalische Parameter

Display	4,3" LCD (hinterleuchtet)
Länge Messbahn	L= 800 mm (min. 200 mm)

Konstruktion	
Schutzart	IP 66 / 69 Konstruktion, IP 66 / 67 / 69 Messgerät
Konstruktion	Edelstahl AISI304
Kommunikationsschnittstellen	
Schnittstellen	RS232, USB
Optionale Schnittstellen	RS232 oder RS485 oder 4IN/4OUT oder Ethernet oder Analogausgang 4-20 mA
Elektrische Parameter	
Stromversorgung	100 – 240 V AC 50/60 Hz
Optionale Stromversorgung	interner Akkumulator
Akku-Betriebszeit	max 7h
Umgebungsbedingungen	
Umgebungstemperatur	-10 – +40 °C
Relative Luftfeuchtigkeit	10% – 85% RH ohne Kondensation



Additional fee for verification



Zubehör (Additional Fee)

Ausgang der Stromschnittstelle AP2-4
Kabel RS 232 (Waage – Drucker)
Displays
Netzkabel (Waage – Ethernet)
Kabel RS 232, RS 485
Netzteile

Konverter RS 232 – Ethernet
USB-Adapter
Thermische Drucker
USB-Kabel (Waage – Drucker)
Wandhalterung, Stativ
Konverter RS 232 – USB

Software (Additional Fee)

- RAD Key [WX-010-0005]
- Scale Editor 2.1 [WX-010-0173]

- RLAB [WX-010-0080]

Abmessungen des Geräts B x T x H

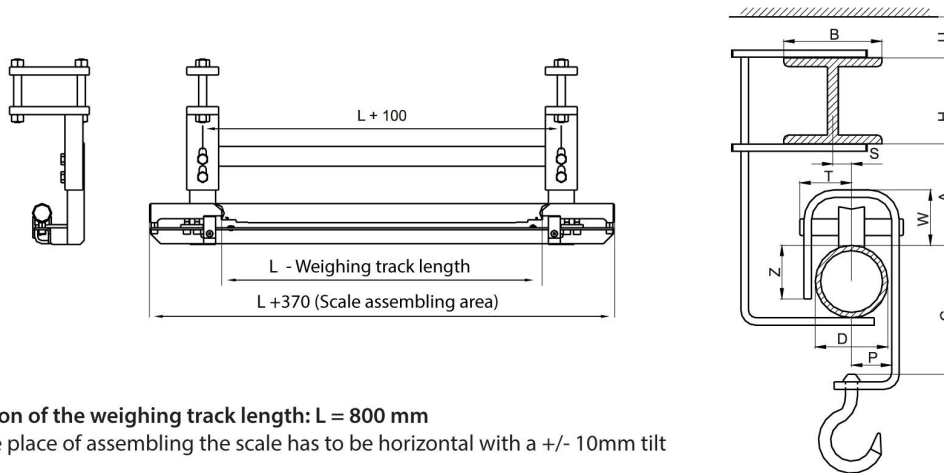

CAUTION

- Standard version of the weighing track length: $L = 800 \text{ mm}$
- The truck in the place of assembling the scale has to be horizontal with a $\pm 10 \text{ mm}$ tilt limit
- The dimensions bearing the letters are to be agreed with contractor manufacturing Z dimension; the dimensions can be omitted if the following relation is fulfilled: $Z \leq 80\% D$

Dimensions of an overhead track scale with a shaft of $\varnothing 60$ (standard version)



Minimum track clearance: $A = 90 \text{ mm}$.

Weighing track length: $200 \leq L \leq 800 \text{ mm}$. As a standard: $L=800 \text{ mm}$.

Maximum capacity: 600 kg .