



More information on the website
mirror.radwag.com/en/info,w1,SE5

C315.K.250.C-1 Chair Scale

WM-003-0007



The drawings, photos and graphics used are for illustrative purposes only.

Functions



Internal battery



Peak hold



GLP Procedures



ALIBI Memory



BMI

Datasheet

Metrological parameters

Maximum capacity [Max]	250 kg
Readability [d]	100 g
Tare range	-250 kg
OIML Class	III

Physical parameters

Display	4.3" LCD (backlit)
Packaging dimensions W x D x H	800×620×1100 mm
Net weight	20 kg
Gross weight	28 kg

Communication interface

Communication interface RS232

Electrical parameters

Power supply 100 – 240 V AC 50/60 Hz and battery

Power consumption max. 5 W

Operation time on batteries up to 8 h

Environmental conditions

Operating temperature 0 – +40 °C

Relative humidity 10% – 85% RH no condensation

According to MDR regulations, this scale is not a medical device.



Additional fee for verification

Accessories (Additional Fee)

Power Adapters

RS 232 cables (scale - printer)

Cigarette lighter receptacle power supply cables

Displays

RS 232, RS 485 cables

RS 232 – Ethernet Converter

RS 232 – USB Converter

RS 232 – RS 485 Converter

Receipt Printer

Software (Additional Fee)

• R-Lab [WX-010-0080]

• Scale Editor 2.1 [WX-010-0173]

Device dimensions W x D x H

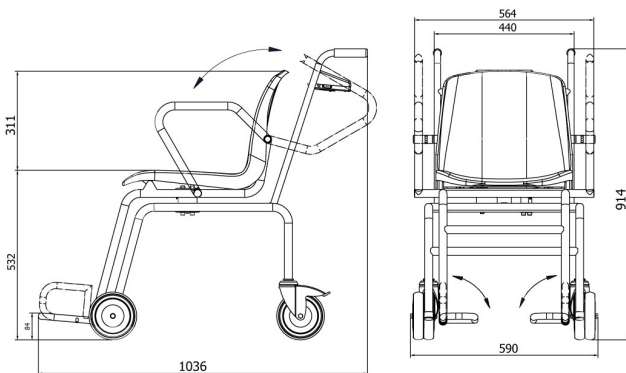

C315.K