



AS 82/220.R2 PLUS Analytical Balance

WL-104-1051

More information on the website
mirror.radwag.com/en/info,w1,RQW



The drawings, photos and graphics used are for illustrative purposes only.

Functions



Autotest



Dosing



Percent Weighing



Totalizing



Parts counting



Peak hold



Newton unit measurement



Statistics



Checkweighing



Under-pan weighing



GLP Procedures



Animal weighing



Density determination

Datasheet

Metrological parameters	
Maximum capacity [Max]	82 / 220 g
Minimum load	1 mg
Readability [d]	0.01 / 0.1 mg
Verification unit [e]	1 mg
Tare range	-220 g
Minimum weight (USP)	24 mg

Metrological parameters	
Minimum weight (U=1%, k=2)	2.4 mg
Standard repeatability [Max]	0.08 mg
Standard repeatability [5% Max]	0.012 mg
Permissible repeatability [Max]	0.1 mg
Permissible repeatability [5% Max]	0.02 mg
Linearity	±0.05 / 0.2 mg
Stabilization time	2 s
Adjustment	internal (automatic)
OIML Class	I
Physical parameters	
Leveling system	manual
Display	5.3" LCD (backlit)
Weighing chamber doors	manual
Delivery components	Balance, weighing pan, weighing pan shield, centring ring, bottom cover, power supply, fabric dust cover.
Weighing pan dimensions	ø90 open-work pan + ø85 (option) mm
Packaging dimensions W x D x H	545x455x575 mm
Net weight	7.3 kg
Gross weight	11 kg
Construction	
Protection class	IP 43
Communication interface	
Communication interface	2×RS232 ¹ , 2×USB-A (interchangeable), USB-B, Wi-Fi (option)
Electrical parameters	
Power supply	Adapter: 100 – 240V AC 50/60Hz 0.6A Max; 12V DC 1.2A Balance: 12 – 15V DC 0.7A max; 3 – 5.5W*
Power consumption max.	3 W
Environmental conditions	
Operating temperature	+10 – +40 °C
Relative humidity	40% – 80%

Repeatability is expressed as a standard deviation from 10 weighing cycles.

Stabilization time depends on the ambient conditions and the dynamics of weighing pan loading; specified for FAST profile.

* Power consumption depends on the terminal configuration as well as the number and type of external devices connected.

¹ Barcode scanners, available as weighing instrument accessory, communicate with the instrument via RS232 interface exclusively.

* Wi-Fi® is a registered trademark of Wi-Fi® Alliance.



Additional fee for verification



Accessories (Additional Fee)

Antivibration Tables
 Holders for laboratory flasks

Balance Storage Case
 RS 232, RS 485 cables

Power Adapters
 Cigarette lighter receptacle power supply cables
 Density determination KIT
 USB cable (scale - printer)
 Professional Weighing Tables
 Barcode scanners
 Holders for test tubes and filters
 Workstation for Pipettes Calibration

Displays
 Protective cover for balances
 Weighing dishes
 Antistatic ionizer
 Receipt Printer
 Under-pan weighing
 RS 232 cables (scale - printer)

Software (Additional Fee)

- RAD Key [WX-010-0005]
- Alibi Reader [WX-010-0114]
- RADWAG Development Studio [WX-010-0104]

- R-Panel [WX-010-0187]
- R-Lab [WX-010-0080]

Device dimensions W x D x H

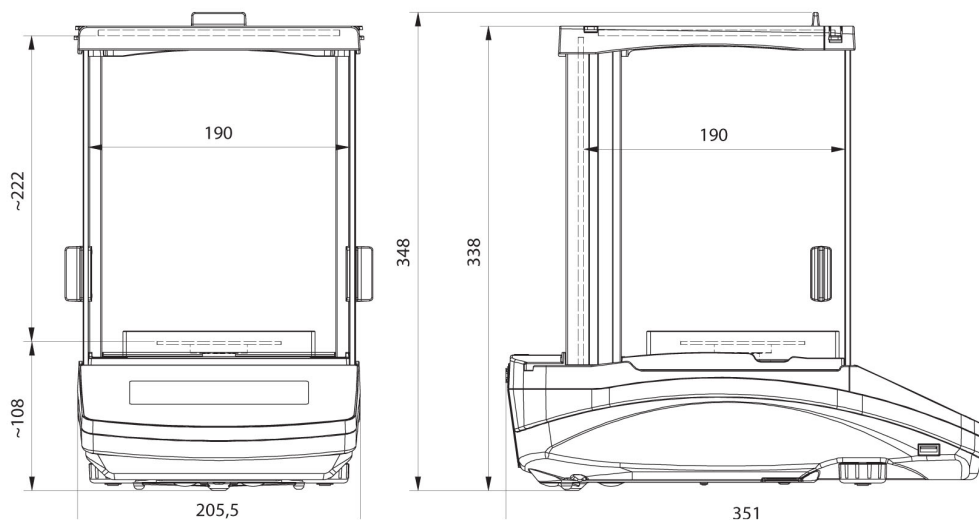

AS R2, d = 0.01 mg

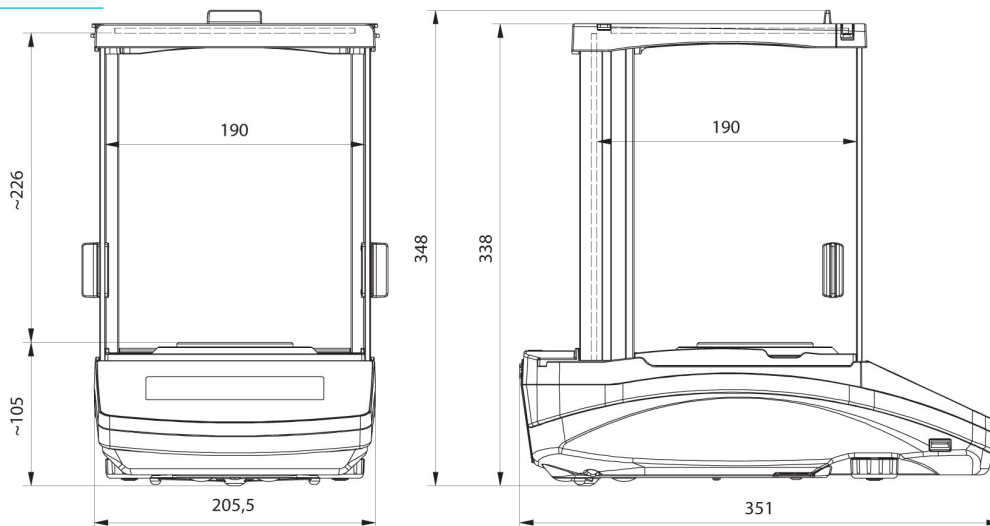

AS R2, AS R1 d = 0.1 mg