



More information on the website
mirror.radwag.com/en/info,w1,R54

MWSH 6000 Weighing Module

WX-016-0106



The drawings, photos and graphics used are for illustrative purposes only.

Datasheet

Metrological parameters	
Maximum capacity [Max]	6000 g
Minimum load	500 mg
Preload range	600 g
Readability [d]	0.01 g
Tare range	-6000 g
Repeatability	15 mg
Linearity	±30 mg
Stabilization time	1.5 s
Adjustment	internal (automatic)
Construction	
Protection class	IP 65
Housing	aluminum, Stainless steel
Communication interface	
Communication interface	RS232, RS485, Ethernet, 2 IN / 2 OUT, PROFIBUS (option), PROFINET (option)

Electrical parameters	
Power supply	100 – 240 V AC 50/60 Hz
Environmental conditions	
Operating temperature	+10 – +40 °C
Relative humidity	15% – 80%
Physical parameters	
Weighing pan dimensions	100×100 mm
Device dimensions	336×175×96 mm
Packaging dimensions	580×335×280 mm

Accessories (Additional Fee)

RS 232 cables (scale - Ethernet)
 RS 232, RS 485 cables
 IN/OUT Cables

Powerbanks
 RS 232 – USB Converter

Software (Additional Fee)

- MWMH Manager [WX-010-0103]
- R-Lab [WX-010-0080]
- RADWAG Development Studio [WX-010-0104]

- RAD Key [WX-010-0005]
- Scale Editor 2.1 [WX-010-0173]

Device dimensions

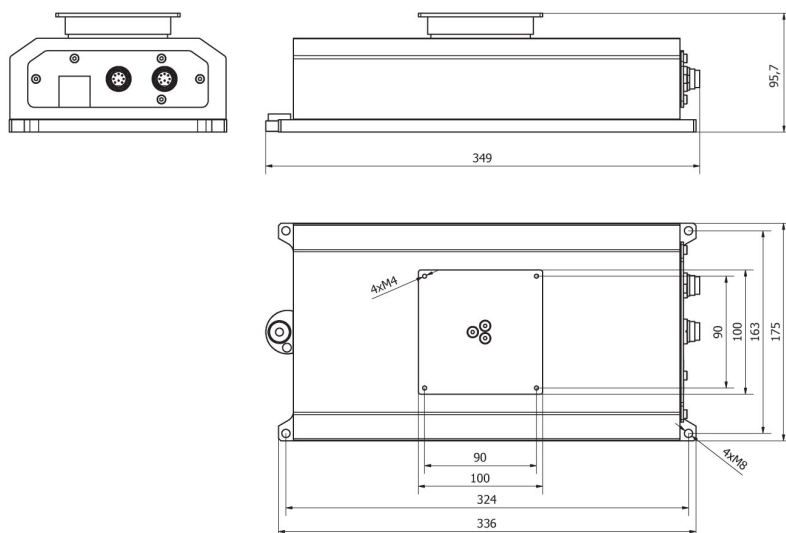

[MWSH](#)