



# HY10.150.2.HRP.H High Resolution Scale

WP-340-1018

More information on the website  
[mirror.radwag.com/us/info,w1,QWX](http://mirror.radwag.com/us/info,w1,QWX)



The drawings, photos and graphics used are for illustrative purposes only.

## Functions

-  Dosing
-  Labelling
-  Plus/Minus Control
-  Percent Weighing
-  Totalizing
-  Parts counting
-  Peak hold
-  Formulation
-  Newton unit measurement
-  Statistics
-  Checkweighing
-  GLP Procedures
-  Animal weighing
-  Differential weighing
-  Replaceable unit
-  Statistical Quality Control
-  ALIBI Memory
-  Transactions

## Datasheet

Metrological parameters	
Maximum capacity [Max]	150 kg
Minimum load	50 g
Preload range	30 kg
Readability [d]	1 g

<b>Metrological parameters</b>	
Tare range	-150 kg
Repeatability	0,6 g
Linearity	±3 g
Stabilization time	3 s
Adjustment	internal (automatic)
<b>Physical parameters</b>	
Display	10,1" graphic colour touchscreen
Weighing pan dimensions	500×500 mm
Packaging dimensions W x D x H	1000×800×307 mm
Net weight	71,5 kg
Gross weight	119 kg
<b>Construction</b>	
Protection class	IP 66 / 67 construction, IP 66 / 67 / 69 terminal
Construction	Stainless steel AISI304
Weighing pan material	Stainless steel AISI304
<b>Communication interface</b>	
Communication interface	2×RS232, 2×USB-A, Ethernet, 4 IN / 4 OUT (digital)
Optional interfaces	module Wi-Fi 802.11 b/g/n, module Profibus (DP SLAVE), module RS485, module PROFINET (RJ45), analog output module (4-20mA, 0-20mA, 0-10V) , 12IN / 12OUT (IN – 5-24 VDC, OUT – max 30 VDC, 0,5 ADC)
<b>Electrical parameters</b>	
Power supply	100 – 240 V AC 50/60 Hz
<b>Environmental conditions</b>	
Operating temperature	+10 – +40 °C
Relative humidity	15% – 80%

\* Wi-Fi® is a registered trademark of Wi-Fi® Alliance.



## Accessories (Additional Fee)

AP2-4 Current Loop Unit  
 Transponder card readers  
 RS 232 cables (scale - ZEBRA printer)  
 RS 232 cables (scale - printer)  
 Ethernet cables (scale - Ethernet)  
 Displays  
 RS 232, RS 485 cables

IN/OUT Cables  
 Stands, wall mounting kits and mounting brackets  
 Keypad, external switches  
 Receipt Printer  
 USB cable (scale - printer)  
 Additional Weighing platforms Module  
 Additional modules

## Software (Additional Fee)

• E2R Weighing [WX-010-0099]  
 • Label Editor R02 [WX-010-0094]

• Audit Trail Reader [WX-010-0186]  
 • RADWAG Remote Desktop [WX-010-0107]

## Device dimensions W x D x H

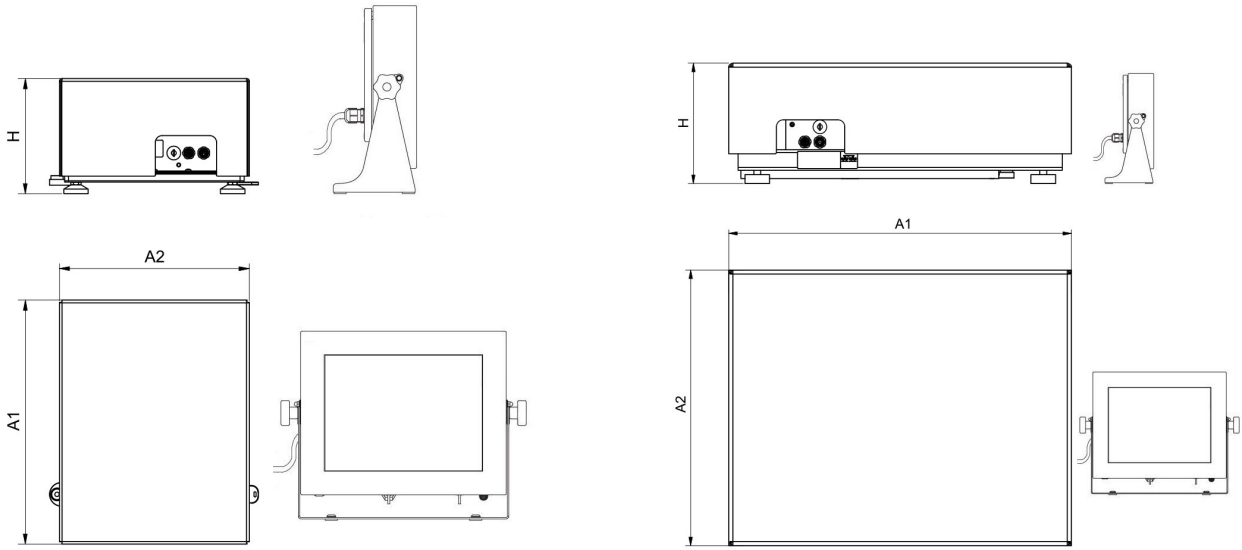

HY10.16 - 32.HRP.H

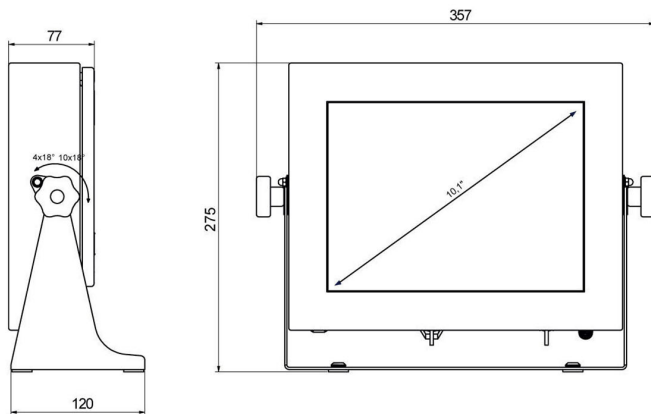

Scale type	A1	A2	H
HY10.(16-32).HRP.H	360	280	180±5
HY10.(62-150).HRP.H	500	400	180±5
HY10.150.2.HRP.H	500	500	180±5
HY10.(150.1-300).HRP.H	800	600	180±5
HY10.(300.1-1100).HRP.H	1000	800	180±5
HY10.(2000).HRP.H	1250	1000	180±5

Dimensions in mm

PUE HY10