



# IM01.EX-9/3 Communication Module

WX-016-0188

More information on the website  
[mirror.radwag.com/en/info,w1,QOK](http://mirror.radwag.com/en/info,w1,QOK)



The drawings, photos and graphics used are for illustrative purposes only.

## Datasheet

Construction	
Protection class	IP 66 / 68 (1.5m)
ATEX Certification	II (2)G [Ex ib] IIC Gb II (2)D [Ex ib] IIIC Db
Housing	aluminum
Communication interface	
Communication interface	2×RS232, USB, 12IN / 12OUT, EtherNet/IP
Electrical parameters	
Power supply	100 – 240 V AC 50/60 Hz
Power consumption max.	10 W
Environmental conditions	
Operating temperature	-10 – +40 °C
Storage temperature	-20 – +60 °C
Relative humidity	10% – 85% RH no condensation

## Physical parameters

Device dimensions W x D x H	222×146×81 mm
Net weight	1.9 kg
Gross weight	2.5 kg



## Compatible with (Additional Fee)

HX5.EX-1.4P2 H Stainless Steel Beam Scales  
HX5.EX-1 HR Stainless Steel 1-Load-Cell Platform Scales  
RS 232 cables (scale - printer)  
HX5.EX-1.4P2 C Beam Scales  
HX5.EX-1.4N Stainless Steel Ramp Scales  
HX5.EX-1.4 C 4-Load-Cell Platform Scales  
HX5.EX-1.4P H Stainless Steel Pallet Scales  
HX5.EX-1.4 H/Z Stainless Steel Platform Scales, Pit Version  
HX5.EX-1 C 1-Load-Cell Platform Scales

HX5.EX-1 H Waterproof Platform Scales  
PUE HX5.EX Weighing Terminal  
HX5.EX-1.4 H Stainless Steel 4-Load-Cell Platform Scales  
RS 232, RS 485 cables  
IN/OUT Cables  
HX5.EX-1.4P C Pallet Scales  
USB adapter  
USB cable (scale - printer)  
RS 232 – USB Converter

## Device dimensions W x D x H

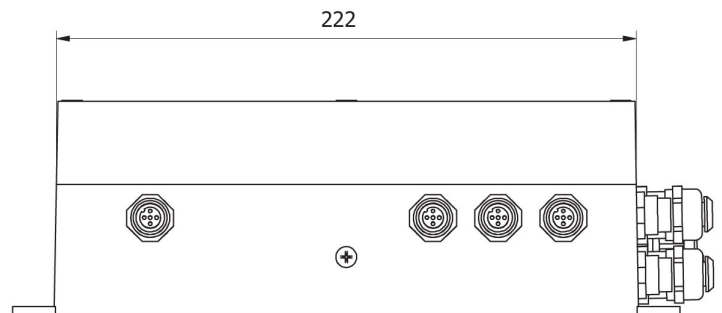
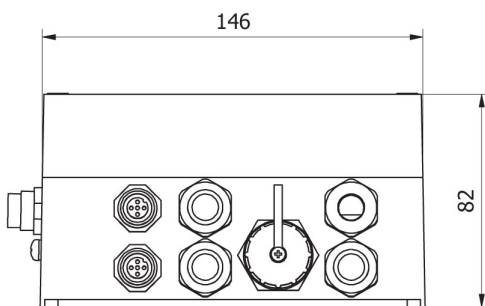

IM01.EX