



More information on the website  
[mirror.radwag.com/en/info,w1,QM0](http://mirror.radwag.com/en/info,w1,QM0)

# AS 160.R2 PLUS Analytical Balance

WL-104-0176



The drawings, photos and graphics used are for illustrative purposes only.

## Functions

-  Autotest
-  Dosing
-  Percent Weighing
-  Totalizing
-  Parts counting
-  Peak hold
-  Newton unit measurement
-  Statistics
-  Checkweighing
-  Under-pan weighing
-  GLP Procedures
-  Animal weighing
-  Density determination

## Datasheet

Metrological parameters	
Maximum capacity [Max]	160 g
Minimum load	10 mg
Readability [d]	0.1 mg
Verification unit [e]	1 mg
Tare range	-160 g
Minimum weight (USP)	140 mg

<b>Metrological parameters</b>	
Minimum weight (U=1%, k=2)	14 mg
Standard repeatability [Max]	0.08 mg
Standard repeatability [5% Max]	0.07 mg
Permissible repeatability [Max]	0.1 mg
Permissible repeatability [5% Max]	0.09 mg
Linearity	±0.2 mg
Stabilization time	2 s
Adjustment	internal (automatic)
OIML Class	I
<b>Physical parameters</b>	
Leveling system	manual
Display	5.3" LCD (backlit)
Weighing chamber doors	manual
Delivery components	Balance, weighing pan, weighing pan shield, centring ring, bottom cover, power supply.
Weighing pan dimensions	ø100 mm
Packaging dimensions W x D x H	490×400×520 mm
Net weight	6.95 kg
Gross weight	9 kg
<b>Construction</b>	
Protection class	IP 43
<b>Communication interface</b>	
Communication interface	2×RS232 <sup>1</sup> , 2×USB-A (interchangeable), USB-B, Wi-Fi (option)
<b>Electrical parameters</b>	
Power consumption max.	3 W
Overtoltage protection	YES
<b>Environmental conditions</b>	
Operating temperature	+10 – +40 °C
Relative humidity	40% – 80%

**Repeatability** is expressed as a standard deviation from 10 weighing cycles.

**Stabilization time** depends on the ambient conditions and the dynamics of weighing pan loading; specified for FAST profile.

\* Power consumption depends on the terminal configuration as well as the number and type of external devices connected.

<sup>1</sup> Barcode scanners, available as weighing instrument accessory, communicate with the instrument via RS232 interface exclusively.

\* Wi-Fi® is a registered trademark of Wi-Fi® Alliance.



Additional fee for verification



## Accessories (Additional Fee)

Antivibration Tables  
 Holders for laboratory flasks

Balance Storage Case  
 RS 232, RS 485 cables

Power Adapters  
 Cigarette lighter receptacle power supply cables  
 Density determination KIT  
 USB cable (scale - printer)  
 Professional Weighing Tables  
 Barcode scanners  
 Holders for test tubes and filters  
 Workstation for Pipettes Calibration

Displays  
 Protective cover for balances  
 Weighing dishes  
 Antistatic ionizer  
 Receipt Printer  
 Under-pan weighing  
 RS 232 cables (scale - printer)

## Software (Additional Fee)

- RAD Key [WX-010-0005]
- Alibi Reader [WX-010-0114]
- RADWAG Development Studio [WX-010-0104]
- R-Panel [WX-010-0187]
- R-Lab [WX-010-0080]

## Device dimensions W x D x H

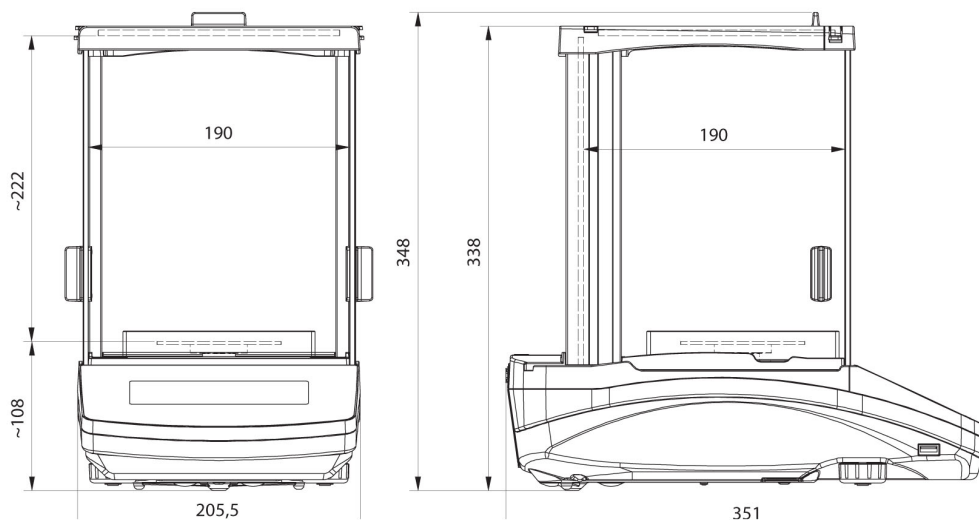

AS R2, d = 0.01 mg

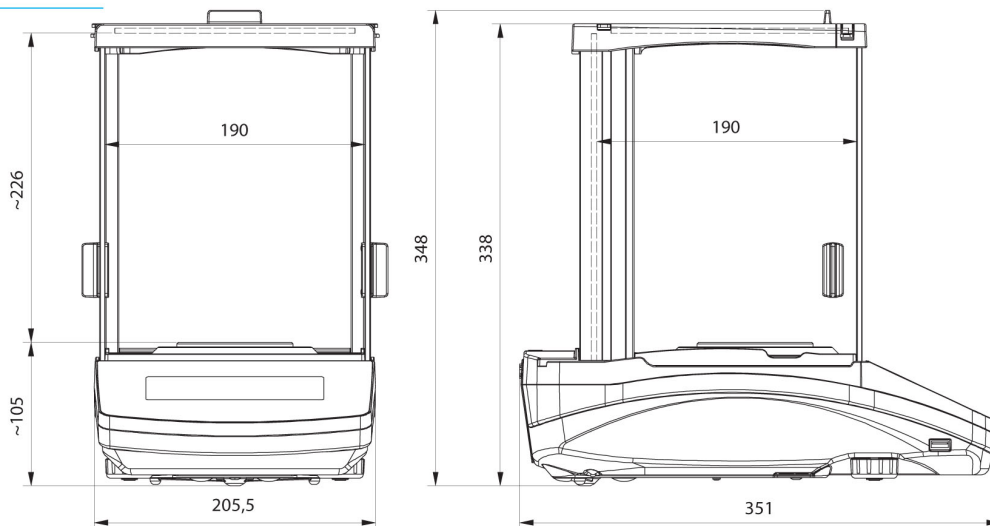

AS R2, AS R1 d = 0.1 mg