



More information on the website  
[mirror.radwag.com/us/info,w1,Q4R](http://mirror.radwag.com/us/info,w1,Q4R)

# IM01.EX-1 Communication Module



The drawings, photos and graphics used are for illustrative purposes only.

## Datasheet

Construction	
Protection class	IP 66 / 68 (1,5m)
Housing	aluminum
ATEX Certification	II (2)G [Ex ib] IIC Gb II (2)D [Ex ib] IIIC Db
Communication interface	
Communication interface	2×RS232, USB, 4IN / 4OUT, Ethernet
Power supply	
Power supply	100 – 240 V AC 50/60 Hz
Power consumption max.	10 W
Operating temperature	
Operating temperature	-10 – +40 °C
Storage temperature	-20 – +60 °C
Relative humidity	10% – 85% RH no condensation
Physical parameters	
Device dimensions	222×146×81 mm
Net weight	1,9 kg

## Physical parameters

Gross weight

2,5 kg



## Compatible with

HX5.EX-1.4P2 H Stainless steel Beam Scales  
HX5.EX-1 HR Stainless Steel 1-Load-Cell Platform Scales  
RS 232 cables (scale - printer)  
HX5.EX-1.4P2 C Beam Scales  
HX5.EX-1.4N Stainless Steel Ramp Scales  
HX5.EX-1.4 C 4-Load-Cell Platform Scales  
HX5.EX-1.4P H Stainless steel pallet scales  
HX5.EX-1.4 H/Z Stainless steel platform scales, pit version  
HX5.EX-1 C 1 Load Cell Platform Scales

HX5.EX-1 H Waterproof Platform Scales  
PUE HX5.EX Weighing Terminal  
HX5.EX-1.4 H Stainless Steel 4-Load-Cell Platform Scales  
RS 232, RS 485 cables  
IN/OUT Cables  
HX5.EX-1.4P C Pallet scales  
USB adapter  
USB cable (scale - printer)  
RS 232 – USB Converter

## Device dimensions

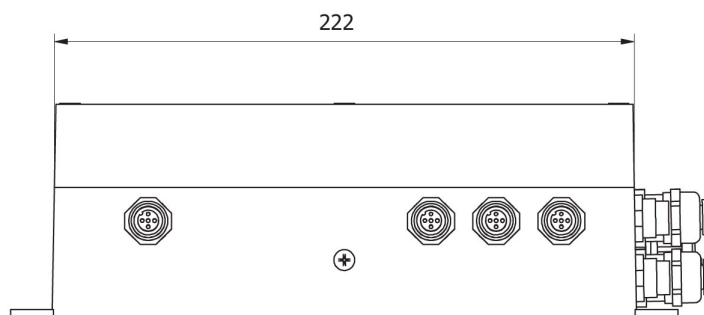
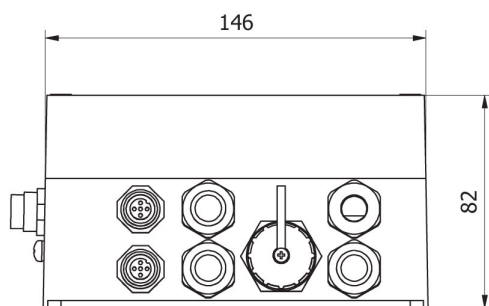

IM01.EX