



More information on the website
mirror.radwag.com/en/info,w1,PES

PUE H315 Weighing Terminal

WX-008-0191



The drawings, photos and graphics used are for illustrative purposes only.

Functions

 Plus/Minus Control

 Percent Weighing

 Totalizing

 Parts counting

 Internal battery

 Peak hold

 Newton unit measurement

 GLP Procedures

 Animal weighing

 ALIBI Memory

Datasheet

Metrological parameters	
OIML Class	III
Maximum quantity of divisions from converter	838 860 ×10
Maximum quantity of verification units	6000 e
Minimum voltage per verification unit	0.4 μV
Maximum voltage per verification unit	3.25 μV
Minimum load cell impedance	50 Ω
Maximum load cell impedance	1200 Ω

Metrological parameters	
Load cell excitation voltage	5V DC
Maximum increase of signal	39 mV
Connection of load cells	4 or 6 wires + ekran
Physical parameters	
Display	4.3" LCD (backlit)
Device dimensions W x D x H	208×145×80 mm
Packaging dimensions W x D x H	300×250×130 mm
Net weight	2 kg
Gross weight	2.2 kg
Construction	
Protection class	IP 66 / 67 / 69
Keypad	microswitch
Housing	Stainless steel
Communication interface	
Communication interface	RS232, USB
Optional interfaces	RS232 or RS485 or 4IN/4OUT or Ethernet or analog output 4-20 mA
Electrical parameters	
Power supply	100 – 240 V AC 50/60 Hz
Optional power supply	internal rechargeable battery
Operation time on batteries	max 7h
Environmental conditions	
Operating temperature	-10 – +40 °C
Storage temperature	-10 – +50 °C
Relative humidity	10% – 80% RH no condensation
Number of buttons	5
Multiple range	1 or 2 ranges
Additional LCD display	WD-4/1 (option)



Compatible with (Additional Fee)

Waterproof stainless steel platforms
Mild steel powder coated weighing platforms
AP2-4 Current Loop Unit
RS 232 cables (scale - printer)
RS 232, RS 485 cables
Displays
Ethernet cables (scale - Ethernet)
Power Adapters

USB adapter
Receipt Printer
Additional modules
USB cable (scale - printer)
Stands, wall mounting kits and mounting brackets
RS 232 – USB Converter
RS 232 – RS 485 Converter

Software (Additional Fee)

Device dimensions W x D x H

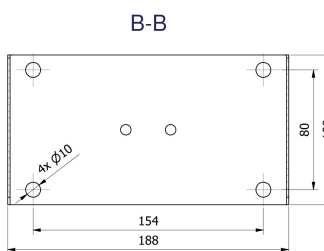
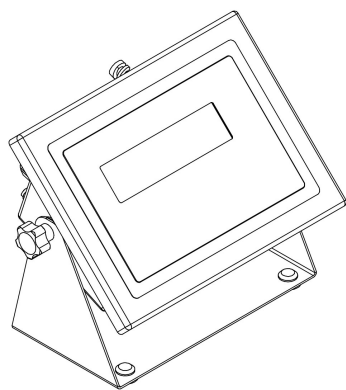
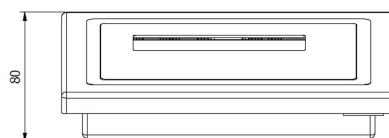
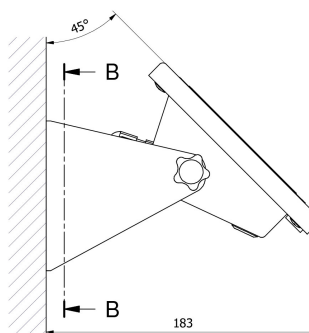
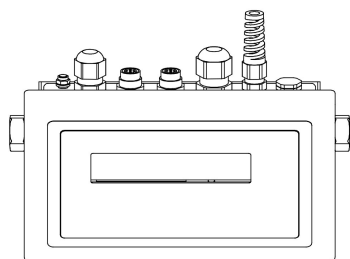
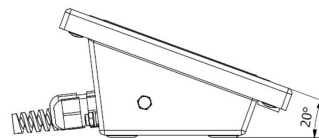
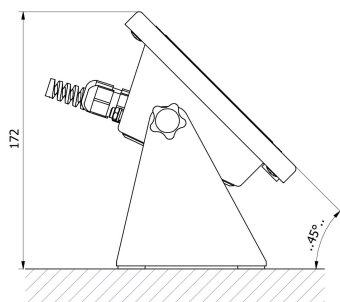
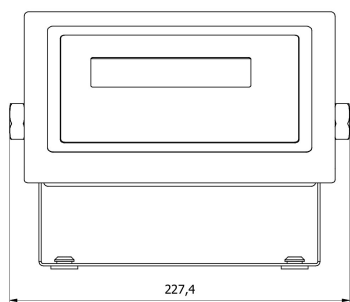

B-B

