



Bilancia multifunzione HY10.3.F1.K

WP-116-0055

More information on the website
mirror.radwag.com/it/info,w1,OUQ



The drawings, photos and graphics used are for illustrative purposes only.

Funzioni

-  Dosing
-  Labelling
-  Plus/Minus Control
-  Percent Weighing
-  Totalizing
-  Parts counting
-  Peak hold
-  Formulation
-  Newton unit measurement
-  Statistics
-  Checkweighing
-  GLP Procedures
-  Animal weighing
-  Differential weighing
-  Replaceable unit
-  Statistical Quality Control
-  ALIBI Memory
-  Transactions

Specifiche

Parametri metrologici

Portata massima [Max]	3 kg
Portata minima [Min]	20 g
Divisione [d]	1 g
Intervallo di verifica della bilancia [e]	1 g

Parametri metrologici	
Campo di tara	-3 kg
Massima leggibilità per bilance non verificate	0,2 g
Calibrazione	external
Classe OIML	III
Parametri fisici	
Display	10,1" graphic colour touchscreen
Lunghezza del cavo	1 m
Dimensione piatto	300x300 mm
Dimensioni del pacco L x P x A	390x570x390 mm
Peso net	10,3 kg
Peso lordo	12,2 kg
Costruzione	
Punteggio IP	IP 65 construction, IP 66 / 67 / 69 terminal
Interfaccia di comunicazione	
Interfaccia	2xRS232, 2xUSB-A, Ethernet, 4 IN / 4 OUT (digital)
Interfacce opzionali	module Wi-Fi 802.11 b/g/n, module Profibus (DP SLAVE), module RS485, module PROFINET (RJ45), analog output module (4-20mA, 0-20mA, 0-10V) , 12IN / 12OUT (IN – 5-24 VDC, OUT – max 30 VDC, 0,5 ADC)
Parametri elettrici	
Alimentatore	100 – 240 V AC 50/60 Hz
Environmental conditions	
Ambiente di lavoro	-10 – +40 °C
Umidità relativa	10% – 85% RH no condensation

* Wi-Fi® is a registered trademark of Wi-Fi® Alliance.



Additional fee for verification



Accessori (Additional Fee)

AP2-4 Modulo di conversione analogica
 Cavo seriale RS 232 (connessione bilance - Stampanti)
 Lettore di tessere transponder
 Cavo seriale RS 232 (connessione bilance - Stampanti ZEBRA)
 Cavi di rete (connessione bilance - Ethernet)
 Display
 Cavo seriale RS 232, RS 485
 Cavi IN/OUT
 Lettore di codici a barre stampanti per etichette

Supporto, set di montaggio a muro e braccetti di montaggio
 Tavoli antivibranti
 Tastiera, interruttori esterni
 Stampanti di ricevuata
 Pesi standard F1 - cilindrici, set
 Cavo USB (connessione bilance - stampanti)
 Moduli aggiuntivi della piattaforma
 Moduli aggiuntivi
 Convertitore RS 232 – USB

Software (Additional Fee)

- E2R Weighing [WX-010-0099]
- Audit Trail Reader [WX-010-0186]

- RAD Key [WX-010-0005]
- Editore di etichette R02 [WX-010-0094]

Device dimensions L x P x A

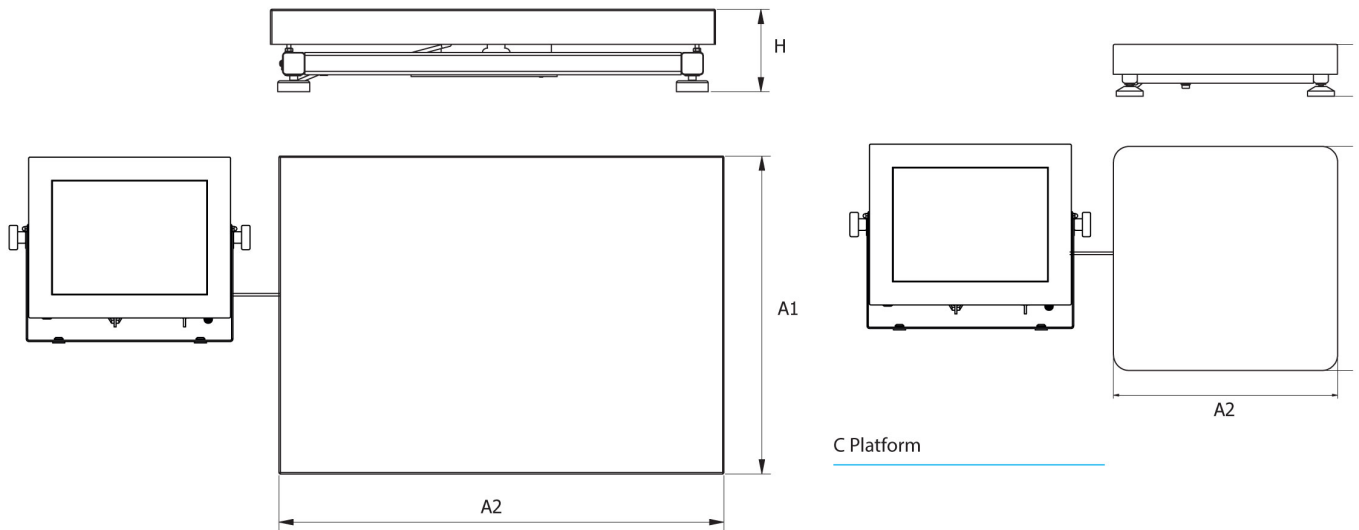

F1 Platform

C Platform

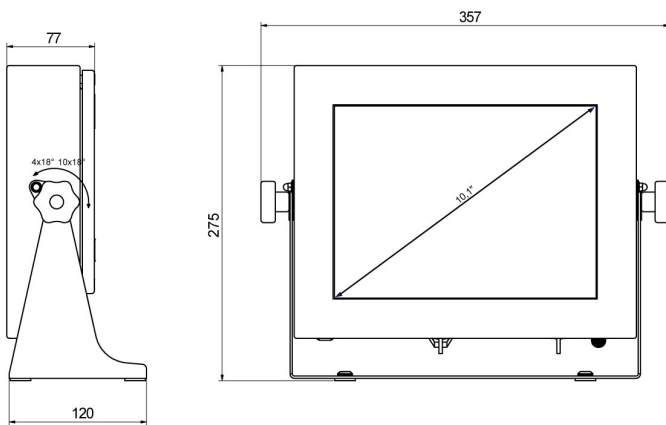

PUE HY10

Scale type	A1	A2	H
HY10.C2.K	400	500	103 ± 3
HY10.C3.K	500	700	130 ± 3
HY10.F1.K	300	300	70 ± 3

dimensions in mm