



PS 200/2000.R2 Precision Balance

WL-212-1003

More information on the website
mirror.radwag.com/en/info,w1,NTZ



The drawings, photos and graphics used are for illustrative purposes only.

Functions



Autotest



Dosing



Percent Weighing



Totalizing



Parts counting



Peak hold



Newton unit measurement



Statistics



Checkweighing



Under-pan weighing



GLP Procedures



Animal weighing



Density determination

Datasheet

Metrological parameters	
Maximum capacity [Max]	200 / 2000 g
Minimum load	20 mg
Readability [d]	1 / 10 mg
Verification unit [e]	10 / 100 mg
Tare range	-2000 g
Minimum weight (USP)	1 g

Metrological parameters	
Minimum weight (U=1%, k=2)	0.1 g
Standard repeatability [Max]	1 / 10 mg
Standard repeatability [5% Max]	0.5 / 5 mg
Linearity	±2 / 20 mg
Stabilization time	2 / 1.5 s
Adjustment	internal (automatic)
OIML Class	II
Sensitivity temperature drift	$2 \times 10^{-6} / ^\circ\text{C} \times \text{Rt}$
Physical parameters	
Leveling system	manual
Display	5.3" LCD (backlit)
Delivery components	Balance, weighing pan, weighing pan shield, grounding bumper x1, bumper x3, power supply.
Weighing pan dimensions	128x128 mm
Packaging dimensions W x D x H	475x380x345 mm
Net weight	4.7 kg
Gross weight	6 kg
Construction	
Protection class	IP 43
Communication interface	
Communication interface	2xRS232 ¹ , USB-A, USB-B, Wi-Fi (option)
Electrical parameters	
Power supply	Adapter: 100 – 240V AC 50/60Hz 0.6A Max; 12V DC 1.2A Balance: 12 – 15V DC 0.7A max; 3 – 5.5W*
Power consumption	4 W
Environmental conditions	
Operating temperature	+10 – +40 °C
Relative humidity	40% – 80%

Repeatability is expressed as a standard deviation from 10 weighing cycles.

Stabilization time depends on the ambient conditions and the dynamics of weighing pan loading; specified for FAST profile.

* Power consumption depends on the terminal configuration as well as the number and type of external devices connected.

¹ Barcode scanners, available as weighing instrument accessory, communicate with the instrument via RS232 interface exclusively.

* Wi-Fi® is a registered trademark of Wi-Fi® Alliance.



Additional fee for verification



Accessories (Additional Fee)

Balance Storage Case
Antivibration Tables
Power Adapters
Cigarette lighter receptacle power supply cables
USB cable (scale - printer)
Density determination KIT

Anti-Draft Chamber for Balances with a 128x128 mm Weighing Pan
RS 232, RS 485 cables
Displays
Receipt Printer
Protective cover for balances
Under-pan weighing

Software (Additional Fee)

- RAD Key [WX-010-0005]
- Alibi Reader [WX-010-0114]
- RADWAG Development Studio [WX-010-0104]

- R-Panel [WX-010-0187]
- R-Lab [WX-010-0080]

Device dimensions W x D x H

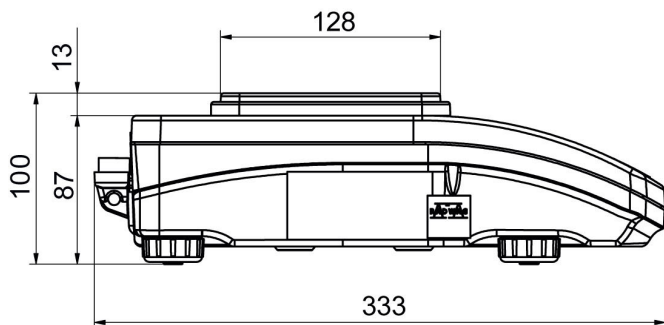

PS R, d = 1mg

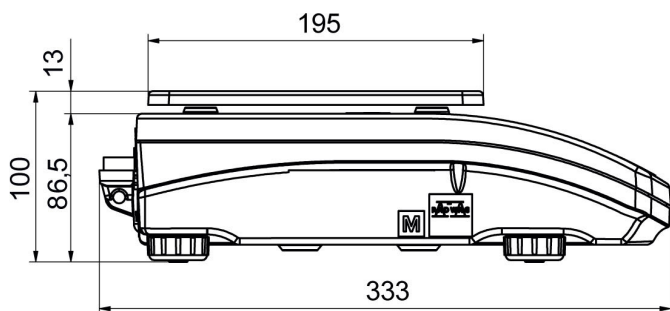
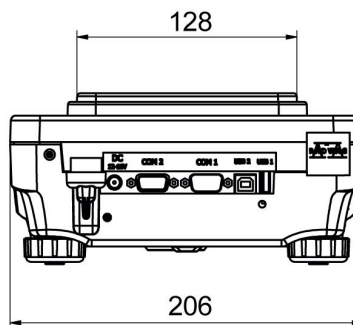

PS R, d = 10 mg

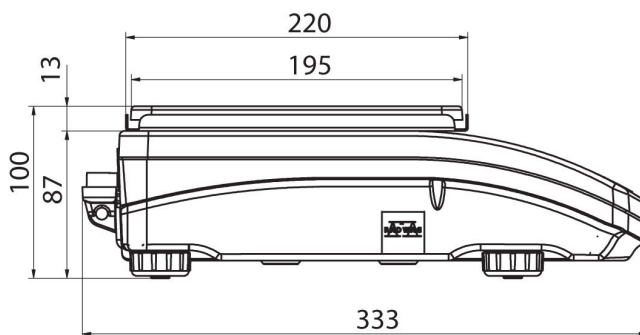
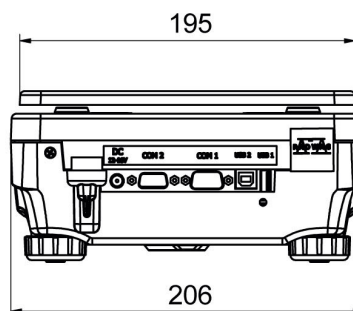

PS R.M, d = 10 mg

