



More information on the website
mirror.radwag.com/us/info,w1,NSA

MAS.1.51 Weighing Module



The drawings, photos and graphics used are for illustrative purposes only.

Datasheet

Maximum capacity [Max]	51 g
Minimum load	1 mg
Preload range	5,1 g
Readability [d]	0,01 mg
Tare range	-51 g
Minimum weight (USP)	24 mg
Minimum weight (U=1%,k=2)	2,4 mg
Repeatability (Max)	0,025 mg
Repeatability (5% Max)	0,012 mg
Linearity	±0,06 mg
Stabilization time	6 s
Construction	
Protection class	IP 54
Communication interface	RS232

Power supply	100 – 240 V AC 50/60 Hz
Operating temperature	+10 – +40 °C
Relative humidity	40% – 80%
Physical parameters	
Weighing pan dimensions	ø33 mm
Device dimensions	289×143×125 mm
Packaging dimensions	650×340×315 mm
Net weight	4,1 kg
Gross weight	6,1 kg



Accessories

Antivibration tables
RS 232, RS 485 cables
Professional Weighing Tables

RS 232 – USB Converter
RS 232, RS 485 cables

Software

- RAD Key [WX-010-0005]
- RADWAG Development Studio [WX-010-0104]

- R Panel [WX-010-0187]

Device dimensions



MAS.1
MAS.1.R



MAS.1



MAS.1.Y

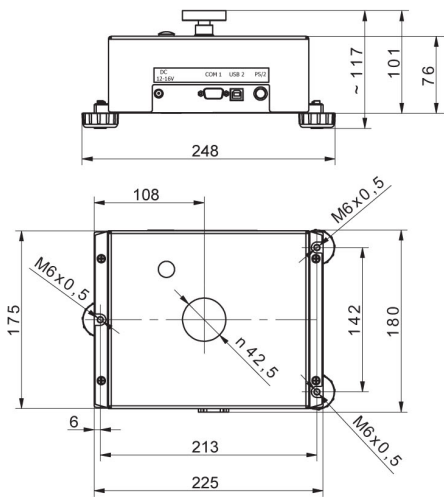

MAS



R operator panel

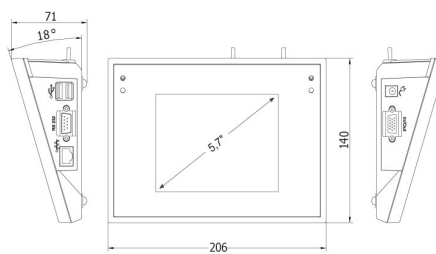

Y operator panel