



More information on the website
mirror.radwag.com/en/info,w1,LZY

AS 220.R1 PLUS Analytical Balance

WL-104-0229



The drawings, photos and graphics used are for illustrative purposes only.

Functions

-  Autotest
-  Dosing
-  Percent Weighing
-  Totalizing
-  Parts counting
-  Peak hold
-  Newton unit measurement
-  Statistics
-  Checkweighing
-  Under-pan weighing
-  GLP Procedures
-  Animal weighing
-  Density determination

Datasheet

Metrological parameters	
Maximum capacity [Max]	220 g
Minimum load	10 mg
Readability [d]	0.1 mg
Tare range	-220 g
Minimum weight (USP)	140 mg
Minimum weight (U=1%, k=2)	14 mg

Metrological parameters	
Standard repeatability [Max]	0.08 mg
Standard repeatability [5% Max]	0.07 mg
Permissible repeatability [Max]	0.1 mg
Permissible repeatability [5% Max]	0.09 mg
Linearity	±0.2 mg
Stabilization time	2 s
Adjustment	external
OIML Class	-
Physical parameters	
Leveling system	manual
Display	5.3" LCD (backlit)
Weighing chamber doors	manual
Delivery components	Balance, weighing pan, weighing pan shield, bottom cover, power supply.
Weighing pan dimensions	ø100 mm
Packaging dimensions W x D x H	490×400×520 mm
Net weight	7.3 kg
Gross weight	9.3 kg
Construction	
Protection class	IP 43
Communication interface	
Communication interface	2×RS232, 2×USB-A (interchangeable), USB-B, Wi-Fi (option)
Electrical parameters	
Power supply	Adapter: 100 – 240V AC 50/60Hz 0.6A; 12V DC 1.2A Balance: 12 – 15V DC 0.4A max
Environmental conditions	
Operating temperature	+10 – +40 °C
Relative humidity	40% – 80%

Repeatability is expressed as a standard deviation from 10 weighing cycles.

Stabilization time depends on the ambient conditions and the dynamics of weighing pan loading; specified for FAST profile.

* Wi-Fi® is a registered trademark of Wi-Fi® Alliance.



Accessories (Additional Fee)

Antivibration Tables
 Holders for laboratory flasks
 Power Adapters
 Cigarette lighter receptacle power supply cables
 Density determination KIT
 USB cable (scale - printer)
 Professional Weighing Tables
 Barcode scanners

Workstation for Pipettes Calibration
 RS 232, RS 485 cables
 Displays
 Weighing dishes
 Antistatic ionizer
 Receipt Printer
 Under-pan weighing
 RS 232 cables (scale - printer)

Software (Additional Fee)

- RAD Key [WX-010-0005]
- Alibi Reader [WX-010-0114]
- RADWAG Development Studio [WX-010-0104]
- R-Panel [WX-010-0187]
- R-Lab [WX-010-0080]

Device dimensions W x D x H

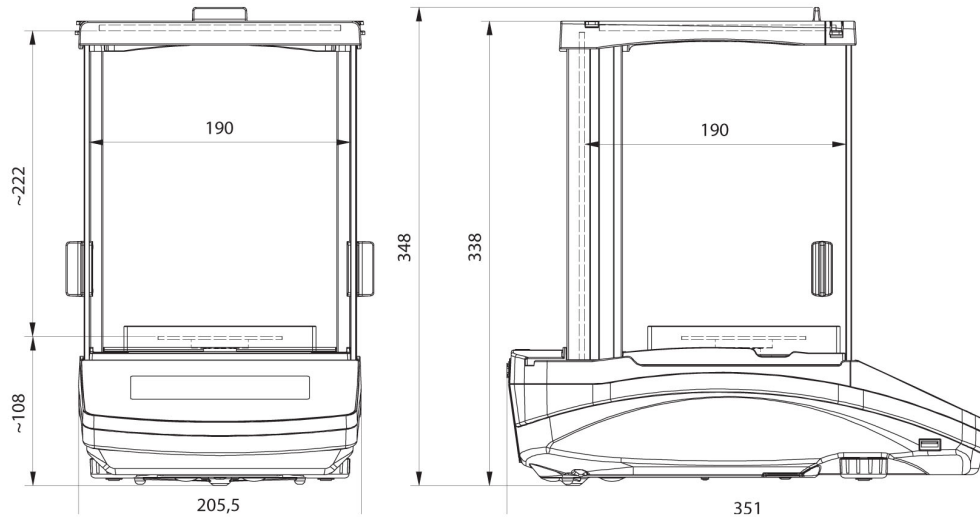

AS R2, d = 0.01 mg

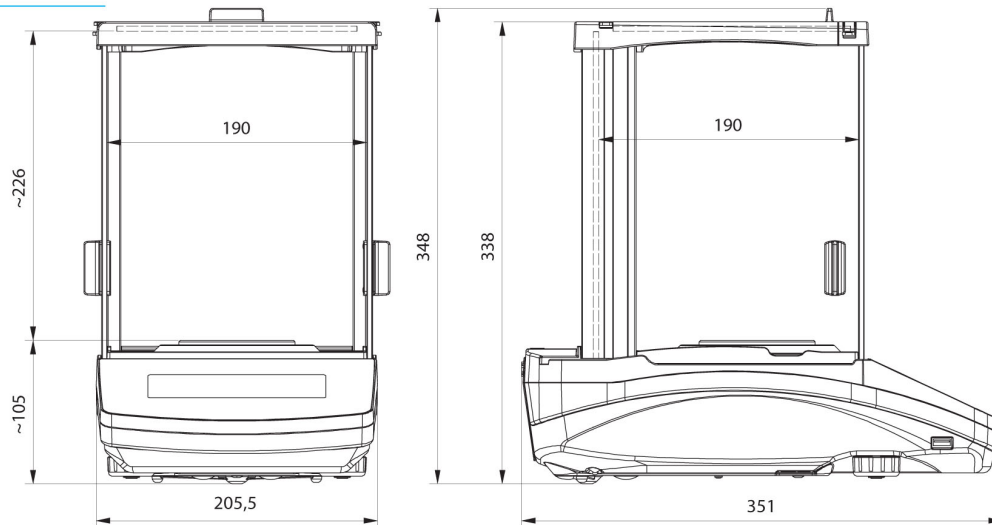

AS R2, AS R1 d = 0.1 mg