



More information on the website
mirror.radwag.com/es/info,w1,K13

Módulo de pesaje MAS.1.82/220



The drawings, photos and graphics used are for illustrative purposes only.

Datos técnicos

Parámetros metrológicos	
Maxima capacidad [Max]	82 / 220 g
Minima capacidad	1 mg
Precarga	8,2 g
Legibilidad [d]	0,01 / 0,1 mg
Rango de tara	-220 g
Pesada mínima usp	40 mg
Pesada mínima	4 mg
Repetibilidad (Max)	0,1 mg
Repetibilidad (5% Max)	0,02 mg
Linealidad	±0,06 / 0,2 mg
Tiempo de estabilización	6 / 2 s
Construcción	
Grado de protección	IP 54

Interface de comunicación	
Conectividad	RS232
Parámetros eléctricos	
Alimentación	100 – 240 V AC 50/60 Hz
Condiciones ambientales	
Temperatura de trabajo	+10 – +40 °C
Humedad relativa de aire	40% – 80%
Parámetros físicos	
Dimensión de platillo	ø42 mm
Dimensiones de aparato	289×143×125 mm
Dimensiones de embalaje	650×340×315 mm
Masa neta	4,1 kg
Masa bruta	6,1 kg



Accesorios

Mesas antivibratil
Cables RS 232, RS 485
Mesas de pesaje profesional

Convertidor RS 232 a USB
Cables RS 232, RS 485

Programas

- RAD Key [WX-010-0005]
- R-LAB [WX-010-0080]

- R Panel [WX-010-0187]
- RADWAG Development Studio [WX-010-0104]

Dimensiones de aparato



MAS.1
MAS.1.R



MAS.1



MAS.1.Y

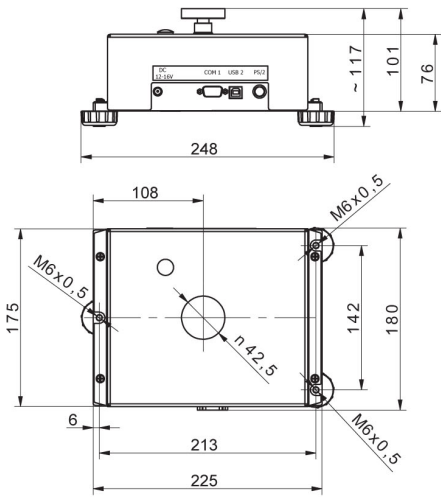

MAS



R operator panel



Y operator panel