



More information on the website
mirror.radwag.com/it/info,w1,K57

MPS 6000.Y Modulo di pesatura



The drawings, photos and graphics used are for illustrative purposes only.

Specifiche

Parametri metrologici	
Portata massima [Max]	6000 g
Divisione [d]	10 mg
Campo di tara	-6000 g
Parametri fisici	
Display	5,7" Resistive Color Touchscreen
Dimensione piatto	ø115 mm
Device dimensions	293×190×112 mm
Dimensioni del pacco	515×340×295 mm
Peso netto	4,8 kg
Parametri elettrici	
Alimentatore	100 – 240 V AC 50/60 Hz
Environmental conditions	
Ambiente di lavoro	+15 – +35 °C
Umidità relativa	40% – 80%



Accessori

Tavoli antivibranti
 Tavolo di pesata professionale
 Cavo seriale RS 232, RS 485

RS 232 – USB Converter
 Cavo seriale RS 232 (connessione bilance - Stampanti)

Software

• RAD Key [WX-010-0005]
 • R-LAB [WX-010-0080]

• R Panel [WX-010-0187]
 • Software „Development Studio” RADWAG [WX-010-0104]

Device dimensions

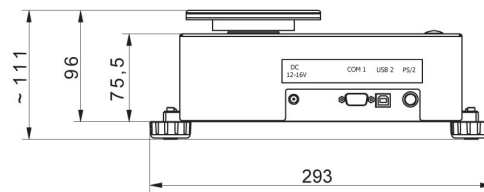
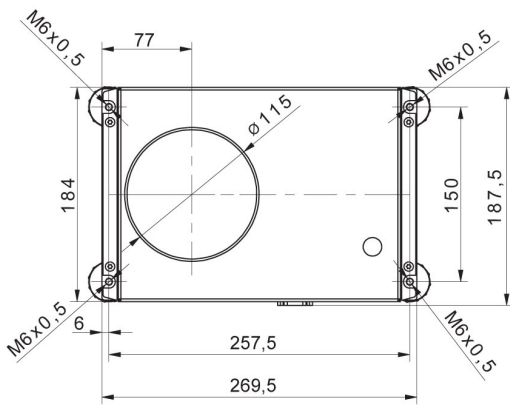

MPS

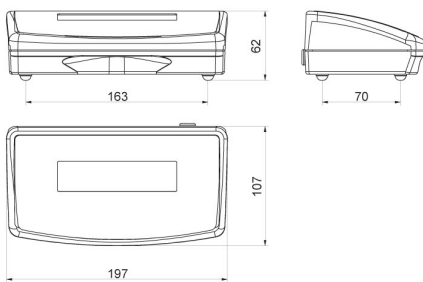

R operator panel

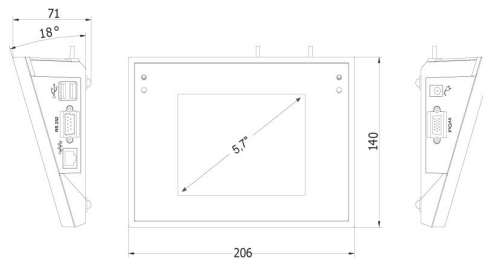

Y operator panel