



More information on the website
mirror.radwag.com/fr/info,w1,K57

Module de balance MPS 6000.Y

WX-016-0071



The drawings, photos and graphics used are for illustrative purposes only.

Paramètres Techniques

Paramètres métrologiques	
Capacité maximale [Max]	6000 g
Précision de lecture [d]	10 mg
Étendue de tare	-6000 g
Paramètres physiques	
Afficheur	5,7" Écran tactile couleur résistif
Dimension du plateau	ø115 mm
Dimensions d'appareil	293×190×112 mm
Dimensions de colis	515×340×295 mm
Masse nette	4,8 kg
Paramètres électriques	
Alimentation	100 – 240 V AC 50/60 Hz
Conditions environnementales	
Température du travail	+15 – +35 °C
Humidité relative d'air	40% – 80%



Accessoires (Additional Fee)

Tables antivibratoires
 Tables de balance professionnelle
 Câbles RS 232, RS 485

Convertisseur RS 232 – USB
 Câbles RS 232 (balance – imprimante)

Software (Additional Fee)

- RAD Key [WX-010-0005]
- R-LAB [WX-010-0080]

- R Panel [WX-010-0187]
- RADWAG Studio du Développement [WX-010-0104]

Dimensions d'appareil

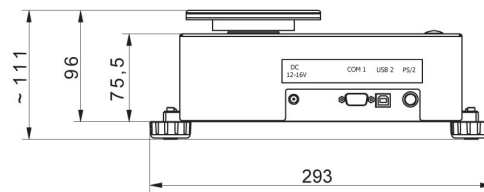
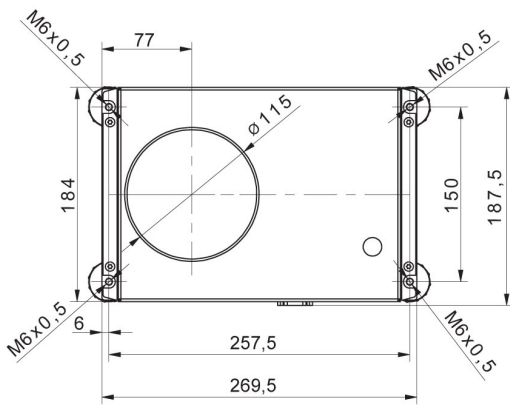

MPS

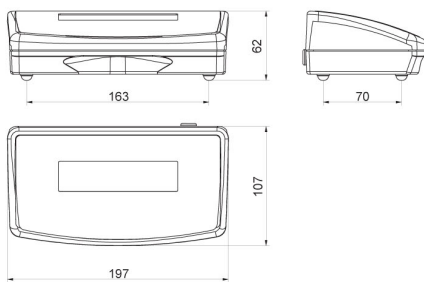

R operator panel

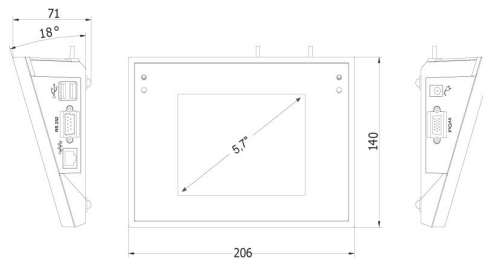

Y operator panel