



More information on the website  
[mirror.radwag.com/en/info,w1,K57](http://mirror.radwag.com/en/info,w1,K57)

# MPS 6000.Y Weighing Module

WX-016-0071



The drawings, photos and graphics used are for illustrative purposes only.

## Datasheet

Metrological parameters	
Maximum capacity [Max]	6000 g
Readability [d]	10 mg
Tare range	-6000 g
Physical parameters	
Display	5.7" resistive colour touchscreen
Weighing pan dimensions	ø115 mm
Device dimensions	293×190×112 mm
Packaging dimensions	515×340×295 mm
Net weight	4.8 kg
Electrical parameters	
Power supply	100 – 240 V AC 50/60 Hz
Environmental conditions	
Operating temperature	+15 – +35 °C
Relative humidity	40% – 80%



## Accessories (Additional Fee)

Antivibration Tables  
 Professional Weighing Tables  
 RS 232, RS 485 cables

RS 232 – USB Converter  
 RS 232 cables (scale - printer)

## Software (Additional Fee)

- RAD Key [WX-010-0005]
- R-Lab [WX-010-0080]

- R-Panel [WX-010-0187]
- RADWAG Development Studio [WX-010-0104]

## Device dimensions

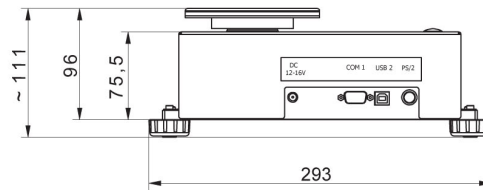
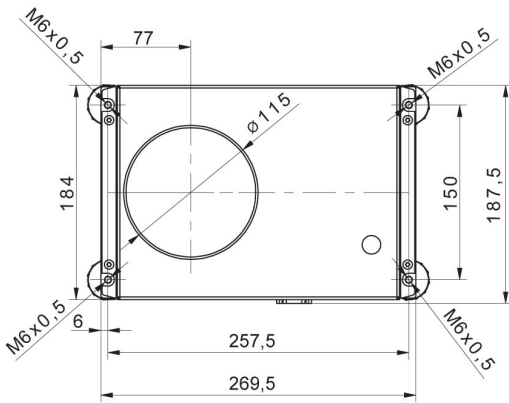

### MPS

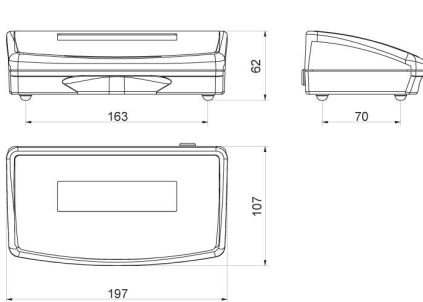

### R operator panel

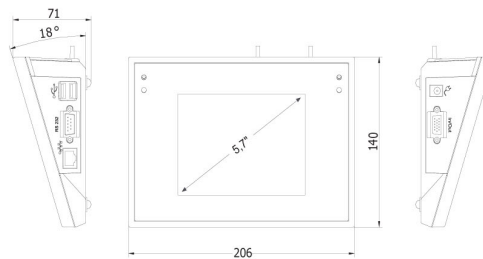

### Y operator panel