



More information on the website
mirror.radwag.com/en/info,w1,JDL

SAL/STONE/C Antivibration Table



The drawings, photos and graphics used are for illustrative purposes only.

Datasheet

Construction	
Construction	mild steel St3S
Load-bearing capacity	150 kg
Physical parameters	
Packaging dimensions	1200×800×970 mm
Net weight	215 kg
Gross weight	242 kg
Length	1000 mm
Width	650 mm
Height	815 mm



Compatible with

H315 HR Waterproof Platform Scale
 MA X7.IC.A Moisture Analyzer
 MUYA Modules
 MAS1 Modules
 XA 5Y.M.A.P Microbalance for pipettes calibration
 WPY Multifunctional Scale
 MYA 5Y.P Microbalance for pipettes calibration
 MA 5Y Moisture Analyzer
 Tunnel Detectors
 C315 Platform scale
 5Y.PM Precision Balance
 MYA 5Y.F Microbalance for Filters
 MA X2.IC.A Moisture Analyzers
 AS X7 Analytical Balance
 PS X2 Precision Balance
 AS X2 PLUS Analytical Balances
 PS X7 Balances for PGC
 XA 5Y.M.A Microbalance
 WLC Precision Balance
 PS R2 Precision Balance
 WLC X7 Precision Balance
 PS X2 Balances for PGC
 H315 H Waterproof Platform Scale
 MA X2.A Moisture Analyzers
 MAS Modules
 MPS Modules
 Susceptometer - Magnetization
 C32.PM Precision Balance
 Automatic Balances for. Pipettes Calibration
 MA X7.A Moisture Analyzer

PS X7 Precision Balance
 XA 5Y.A Analytical Balance
 WAY 5Y.KO Manual Mass Comparator
 UYA 5Y Ultra-Microbalance
 MA 5Y.IC Moisture Analyzer
 MA R Moisture Analyzer
 AS 5Y Analytical Balance
 AK-4 Automatic Mass Comparator
 PS 5Y Balances for PGC
 PS R2.H Precision Balance
 WTC Precision Balance
 XA 5Y.F Analytical Balance for Filters
 WLY Precision Balance
 UMA Automatic Mass Comparator
 Density Measurement
 WLC C/2 Precision Balance
 MYA 5Y Microbalance
 PS R1 Precision Balance
 XA 5Y Analytical Balance
 AS R2 PLUS Analytical Balance
 PS 5Y Precision Balance
 PMV 5Y Moisture Analyzer
 XA 5Y.KO Manual Mass Comparator
 XA 5Y.M Microbalance
 UYA 5Y.KO Manual Mass Comparator
 AS R1 PLUS Analytical Balance
 UYA 5Y.F Ultra-Microbalance for Filters
 APP 5Y.KO Manual Mass Comparator
 Nano-Comparator NANO.AK-4.500.5Y
 XA 5Y.M.A.S Microbalance for stents weighing

Device dimensions

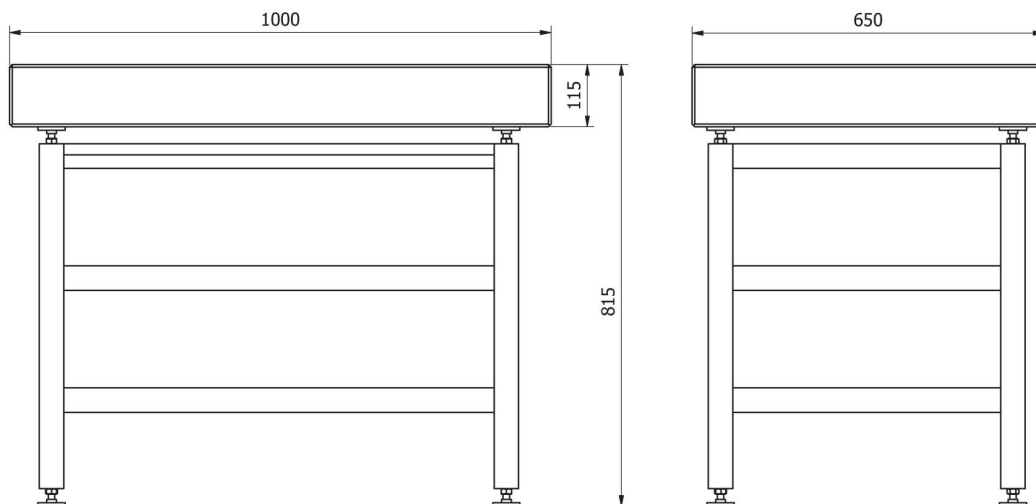

SAL/STONE