



# PS 750.R1 Precision Balance

WL-213-0022

More information on the website  
[mirror.radwag.com/us/info,w1,HUB](http://mirror.radwag.com/us/info,w1,HUB)



The drawings, photos and graphics used are for illustrative purposes only.

## Functions

-  Autotest
-  Dosing
-  Percent Weighing
-  Totalizing
-  Parts counting
-  Peak hold
-  Newton unit measurement
-  Statistics
-  Checkweighing
-  Under-pan weighing
-  GLP Procedures
-  Animal weighing
-  Density determination

## Datasheet

Metrological parameters	
Maximum capacity [Max]	750 g
Minimum load	20 mg
Readability [d]	0,001 g
Tare range	-750 g
Repeatability (Max)	0,0015 g
Repeatability (5% Max)	0,0005 g

Metrological parameters	
Linearity	±0,003 g
Stabilization time	2 s
Adjustment	external
Sensitivity temperature drift	$2 \times 10^{-6} / ^\circ\text{C} \times \text{Rt}$
Physical parameters	
Leveling system	manual
Display	5,3" LCD (backlit)
Delivery components	Balance, weighing pan, weighing pan shield, grounding bumper ×1, bumper ×3, power supply.
Weighing pan dimensions	128×128 mm
Packaging dimensions W x D x H	475×380×345 mm
Net weight	3,2 kg
Gross weight	4,5 kg
Construction	
Protection class	IP 43
Communication interface	
Communication interface	2×RS232 <sup>1</sup> , USB-A, USB-B, Wi-Fi (option)
Electrical parameters	
Power supply	Adapter: 100 – 240V AC 50/60Hz 0,6A; 12V DC 1,2A Balance: 12 – 15V DC 0,4A max
Power consumption	4 W
Environmental conditions	
Operating temperature	+10 – +40 °C
Relative humidity	40% – 80%

\* Wi-Fi® is a registered trademark of Wi-Fi® Alliance.



## Accessories (Additional Fee)

!Balance Storage Case	RS 232, RS 485 cables
Antivibration tables	Displays
Power Adapters	Draft Shield
Cigarette lighter receptacle power supply cables	Receipt Printer
USB cable (scale - printer)	Protective cover for balances
Density determination KIT	Under-pan weighing
Barcode scanners	RS 232 cables (scale - printer)
Anti-draft Chamber for balances with a weighing pan 128×128mm	

## Software (Additional Fee)

- RAD Key [WX-010-0005]
- Alibi Reader PC Software [WX-010-0114]
- R Panel [WX-010-0187]
- RADWAG Development Studio [WX-010-0104]

## Device dimensions W x D x H

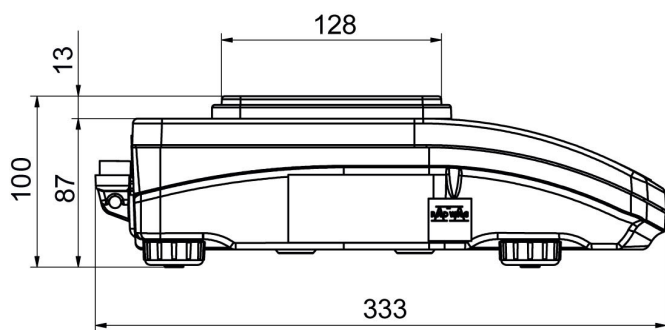

PS R, d = 1mg

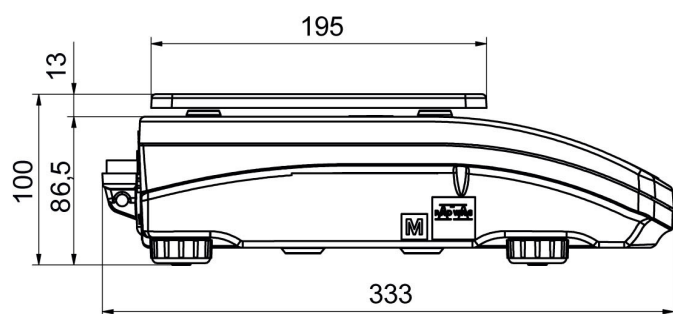
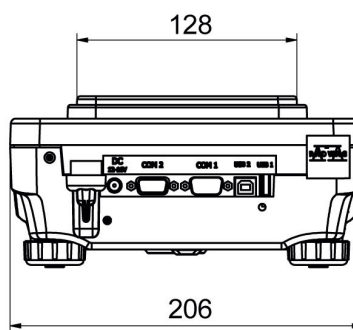

PS R, d = 10 mg

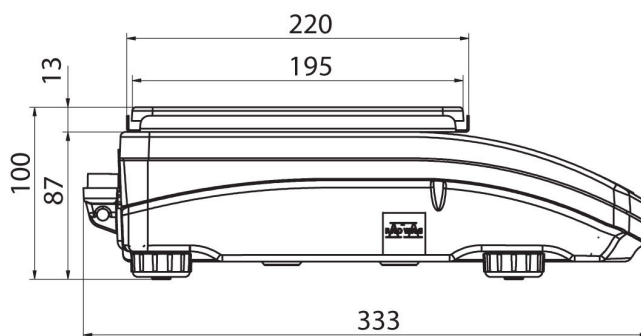
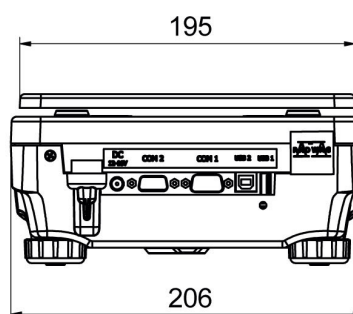

PS R.M, d = 10 mg

