

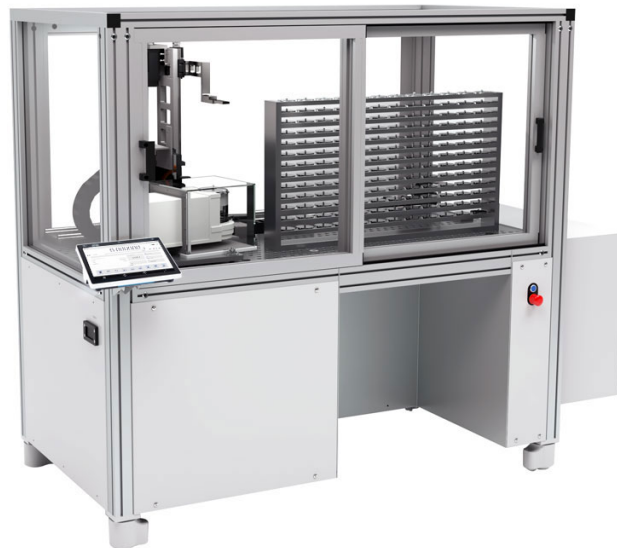

More information on the website
mirror.radwag.com/en/info,w1,GW5

RMC 2.5Y.F Robotic Weighing System



The drawings, photos and graphics used are for illustrative purposes only.

Datasheet

Metrological parameters	
Maximum capacity [Max]	2.1 g
Readability [d]	1 µg
Verification unit [e]	1 mg
Tare range	-2.1 g
Repeatability (Max)	1 – 2 µg
Repeatability (5% Max)	0.5 µg
Linearity	≤ 1.5 µg
Stabilization time	10 - 20 s
Adjustment	internal
OIML Class	I
Physical parameters	
Display	10" graphic colour touchscreen
Device dimensions	2108×1067×1595 mm
Net weight	400 kg
Gross weight	500 kg

Features of use	
Touch-free operation	2 IR Sensors
Communication interface	
Communication interface	2×USB-A, USB-C, HDMI, Ethernet, Wi-Fi, Hotspot
Electrical parameters	
Power supply	110 – 240 V AC 50/60 Hz
Environmental conditions	
Operating temperature	+10 – +40 °C
Storage temperature	-20 – +50 °C
Operating temperature change rate	±0.3 °C / 1 h (±1 °C / 8 h)
Relative humidity	30% – 70%
Relative humidity change rate	±1% / h (±4% / 8 h)
Construction	
Keypad	8 buttons

Repeatability is expressed as a standard deviation from 10 weighing cycles.

Stabilization time depends on the ambient conditions and the dynamics of weighing pan loading; specified for FAST profile.

* Wi-Fi® is a registered trademark of Wi-Fi® Alliance.



Accessories

RFID Tags
 Additional modules
 Protective cover for balances

RS 232, RS 485 cables
 Receipt Printer
 Fingerprint Reader

Software

• Scale Editor 2.1 [WX-010-0173]

Device dimensions

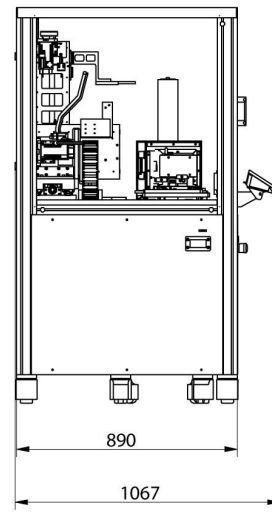
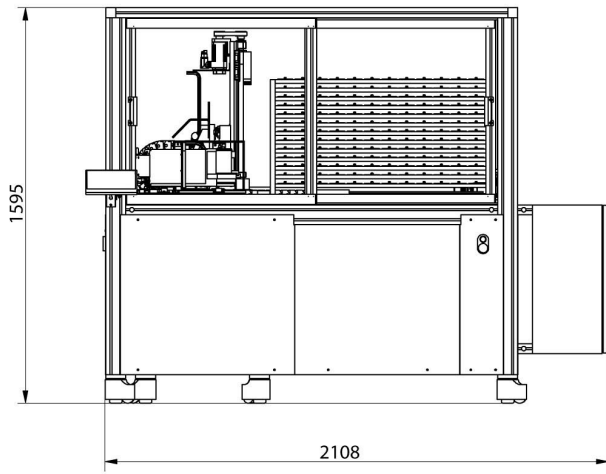

RMC 2.4Y.F

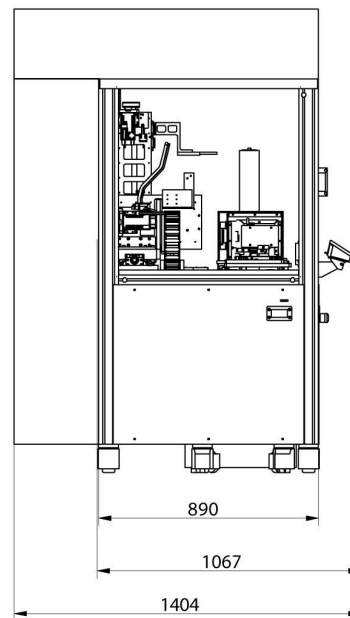
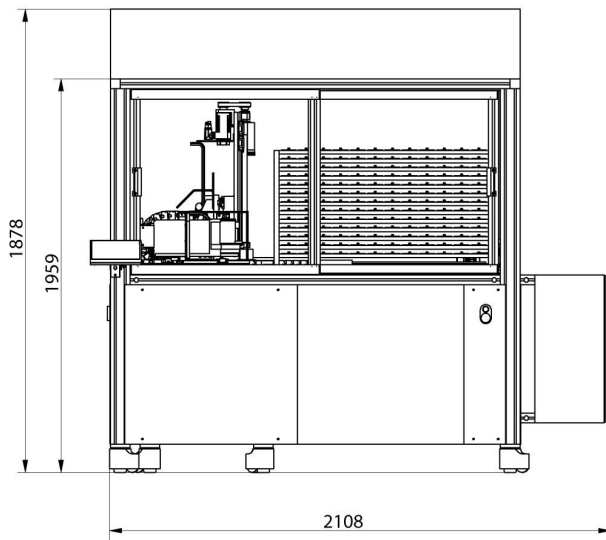

RMC 2.4Y.FC