



More information on the website
mirror.radwag.com/us/info,w1,FV8

MPS 2000 Weighing Module



The drawings, photos and graphics used are for illustrative purposes only.

Datasheet

Maximum capacity [Max]	2000 g
Minimum load	20 mg
Preload range	200 g
Readability [d]	1 mg
Tare range	-2000 g
Repeatability	0,5 mg
Linearity	±4 mg
Stabilization time	3 s
Adjustment	internal (automatic)
Construction	
Protection class	IP 32
Housing	aluminum
Communication interface	RS232, USB-B
Power supply	100 – 240 V AC 50/60 Hz

Operating temperature +10 – +40 °C

Relative humidity 40% – 80%

Physical parameters

Weighing pan dimensions $\varnothing 115$ mm

Device dimensions 293×190×112 mm

Packaging dimensions 515×340×285 mm

Net weight 4,1 kg



Accessories

Antivibration tables
Professional Weighing Tables
RS 232, RS 485 cables

RS 232 – USB Converter
RS 232 cables (scale - printer)

Software

• RAD Key [WX-010-0005]
• RADWAG Development Studio [WX-010-0104]

• R Panel [WX-010-0187]

Device dimensions

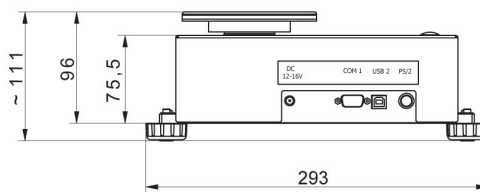
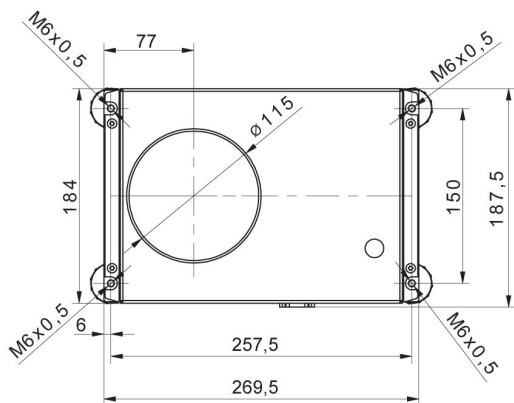

MPS

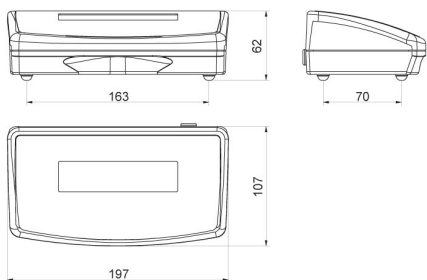

R operator panel

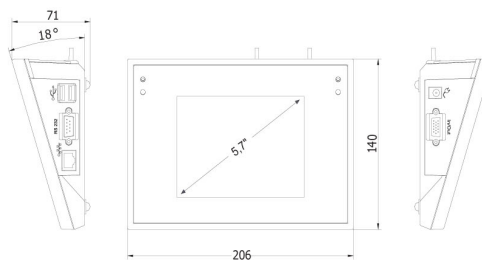

Y operator panel