



More information on the website
mirror.radwag.com/it/info,w1,FV8

MPS 2000 Modulo di pesatura

WX-016-0235



The drawings, photos and graphics used are for illustrative purposes only.

Specifiche

Parametri metrologici	
Portata massima [Max]	2000 g
Portata minima [Min]	20 mg
Intervallo di precarico	200 g
Divisione [d]	1 mg
Campo di tara	-2000 g
Ripetibilita	0,5 mg
Linearità	±4 mg
Tempo di stabilizzazione	3 s
Calibrazione	internal (automatic)
Costruzione	
Punteggio IP	IP 32
Struttura	aluminum
Interfaccia di comunicazione	
Interfaccia	RS232, USB-B

Parametri elettrici	
Alimentatore	100 – 240 V AC 50/60 Hz
Environmental conditions	
Ambiente di lavoro	+10 – +40 °C
Umidità relativa	40% – 80%
Parametri fisici	
Dimensione piatto	ø115 mm
Device dimensions	293×190×112 mm
Dimensioni del pacco	515×340×285 mm
Peso net	4,1 kg



Accessori (Additional Fee)

Tavoli antivibranti
Tavolo di pesata professionale
Cavo seriale RS 232, RS 485

RS 232 – USB Converter
Cavo seriale RS 232 (connessione bilance - Stampanti)

Software (Additional Fee)

- RAD Key [WX-010-0005]
- R-LAB [WX-010-0080]

- R Panel [WX-010-0187]
- Software „Development Studio“ RADWAG [WX-010-0104]

Device dimensions

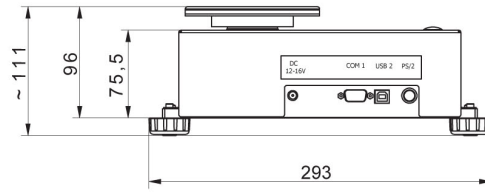
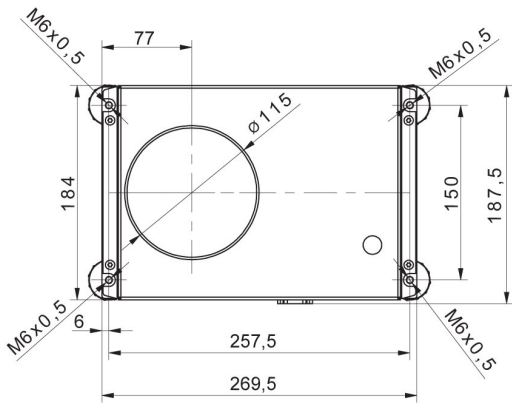

MPS

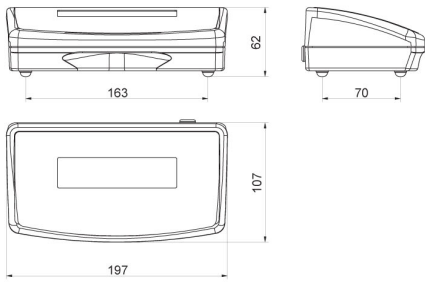

R operator panel

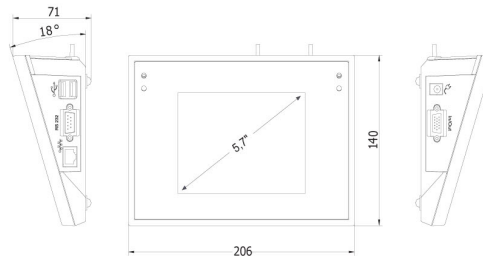

Y operator panel