



More information on the website
mirror.radwag.com/en/info,w1,FV8

MPS 2000 Weighing Module

WX-016-0235



The drawings, photos and graphics used are for illustrative purposes only.

Datasheet

Metrological parameters	
Maximum capacity [Max]	2000 g
Minimum load	20 mg
Preload range	200 g
Readability [d]	1 mg
Tare range	-2000 g
Repeatability	0.5 mg
Linearity	±4 mg
Stabilization time	3 s
Adjustment	internal (automatic)
Construction	
Protection class	IP 32
Housing	aluminum
Communication interface	
Communication interface	RS232, USB-B

Electrical parameters	
Power supply	100 – 240 V AC 50/60 Hz
Environmental conditions	
Operating temperature	+10 – +40 °C
Relative humidity	40% – 80%
Physical parameters	
Weighing pan dimensions	ø115 mm
Device dimensions	293×190×112 mm
Packaging dimensions	515×340×285 mm
Net weight	4.1 kg



Accessories (Additional Fee)

Antivibration Tables
Professional Weighing Tables
RS 232, RS 485 cables

RS 232 – USB Converter
RS 232 cables (scale - printer)

Software (Additional Fee)

- RAD Key [WX-010-0005]
- R-Lab [WX-010-0080]

- R-Panel [WX-010-0187]
- RADWAG Development Studio [WX-010-0104]

Device dimensions

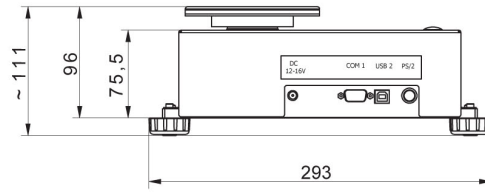
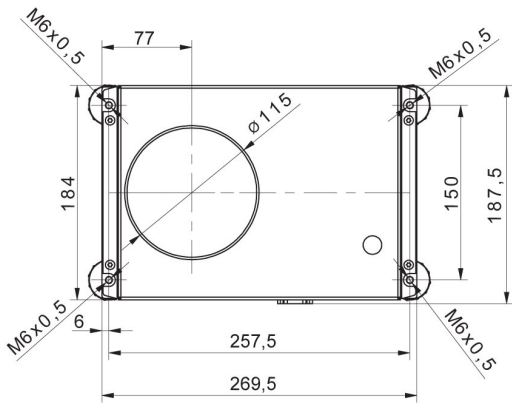

MPS

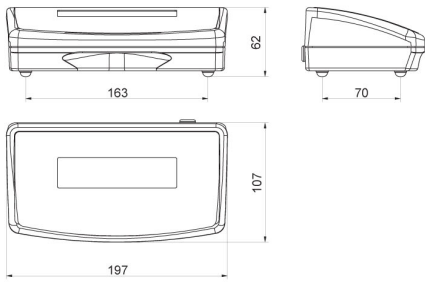

R operator panel

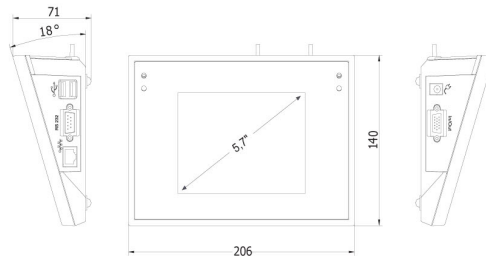

Y operator panel