



More information on the website
mirror.radwag.com/de/info,w1,FV8

Wägemodul MPS 2000



The drawings, photos and graphics used are for illustrative purposes only.

Technische Daten

Messtechnische Parameter	
Wägebereich [Max]	2000 g
Min. Belastung	20 mg
Vorlast	200 g
Zifferschritt [d]	1 mg
Tarierbereich	-2000 g
Wiederholbarkeit	0,5 mg
Linearität	±4 mg
Stabilisierungszeit	3 s
Justierung	intern (automatisch)
Konstruktion	
Schutzart	IP 32
Gehäuse	Aluminum
Kommunikationsschnittstellen	
Schnittstellen	RS232, USB-B

Elektrische Parameter	
Stromversorgung	100 – 240 V AC 50/60 Hz
Umgebungsbedingungen	
Umgebungstemperatur	+10 – +40 °C
Relative Luftfeuchtigkeit	40% – 80%
Physikalische Parameter	
Waagschale	ø115 mm
Abmessungen des Geräts	293×190×112 mm
Verpackungsgröße	515×340×285 mm
Nettogewicht	4,1 kg



Zubehör

Antivibrationstische
 Professionelle Wägestationen
 Kabel RS 232, RS 485

Konverter RS 232 – USB
 Kabel RS 232 (Waage – Drucker)

Software

- RAD Key [WX-010-0005]
- RLAB [WX-010-0080]

- R Panel [WX-010-0187]
- RADWAG Development Studio [WX-010-0104]

Abmessungen des Geräts

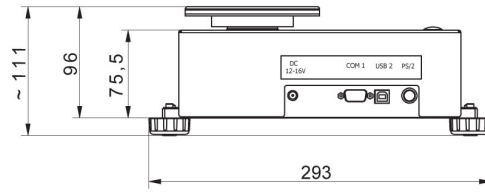
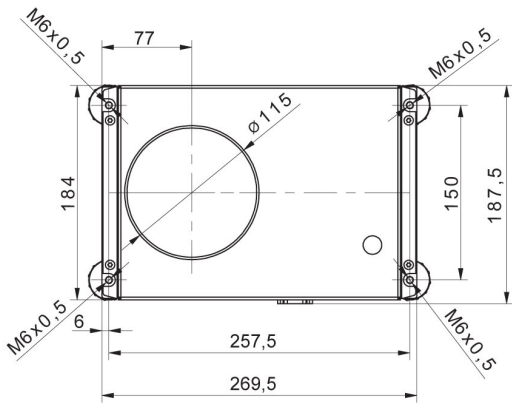

MPS

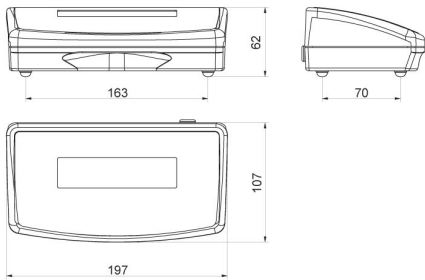

R operator panel

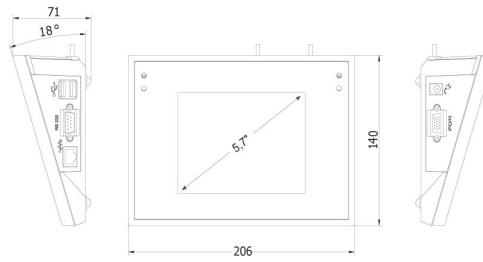

Y operator panel