



More information on the website  
[mirror.radwag.com/en/info,w1,FPZ](http://mirror.radwag.com/en/info,w1,FPZ)

# PS 6100.R2.M.H Precision Balance

WL-221-0026



The drawings, photos and graphics used are for illustrative purposes only.

## Functions

-  Autotest
-  Dosing
-  Percent Weighing
-  Totalizing
-  Parts counting
-  Peak hold
-  Newton unit measurement
-  Statistics
-  Checkweighing
-  Under-pan weighing
-  GLP Procedures
-  Animal weighing
-  Density determination

## Datasheet

Metrological parameters	
Maximum capacity [Max]	6100 g
Minimum load	500 mg
Readability [d]	0.01 g
Tare range	-6100 g
Minimum weight (USP)	10 g
Minimum weight (U=1%, k=2)	1 g

Metrological parameters	
Standard repeatability [5% Max]	0.005 g
Repeatability (Max)	0.008 g
Linearity	±0.03 g
Stabilization time	1.5 s
Adjustment	internal (automatic)
Sensitivity temperature drift	$2 \times 10^{-6} / ^\circ\text{C} \times \text{Rt}$
Physical parameters	
Leveling system	manual
Display	5.3" LCD (backlit)
Delivery components	Balance, weighing pan, weighing pan shield, power supply
Weighing pan dimensions	195×195 mm
Packaging dimensions W x D x H	475×380×345 mm
Net weight	4.8 kg
Gross weight	6.3 kg
Construction	
Protection class	IP 54
Communication interface	
Communication interface	2×RS232 <sup>1</sup> , USB-A, USB-B, Wi-Fi (option)
Electrical parameters	
Power supply	Adapter: 100 – 240V AC 50/60Hz 0.6A Max; 12V DC 1.2A Balance: 12 – 15V DC 0.7A max; 3 – 5.5W*
Power consumption	4 W
Environmental conditions	
Operating temperature	+10 – +40 °C
Relative humidity	40% – 80%

**Repeatability** is expressed as a standard deviation from 10 weighing cycles.

**Stabilization time** depends on the ambient conditions and the dynamics of weighing pan loading; specified for FAST profile.

<sup>1</sup> Barcode scanners, available as weighing instrument accessory, communicate with the instrument via RS232 interface exclusively.

\* Wi-Fi® is a registered trademark of Wi-Fi® Alliance.



## Accessories (Additional Fee)

Antivibration Tables  
Power Adapters  
Cigarette lighter receptacle power supply cables  
USB cable (scale - printer)  
Barcode scanners  
RS 232, RS 485 cables

Displays  
Receipt Printer  
Protective cover for balances  
Under-pan weighing  
RS 232 cables (scale - printer)

## Software (Additional Fee)

- RAD Key [WX-010-0005]
- Alibi Reader [WX-010-0114]
- RADWAG Development Studio [WX-010-0104]

- R-Panel [WX-010-0187]
- R-Lab [WX-010-0080]

## Device dimensions W x D x H

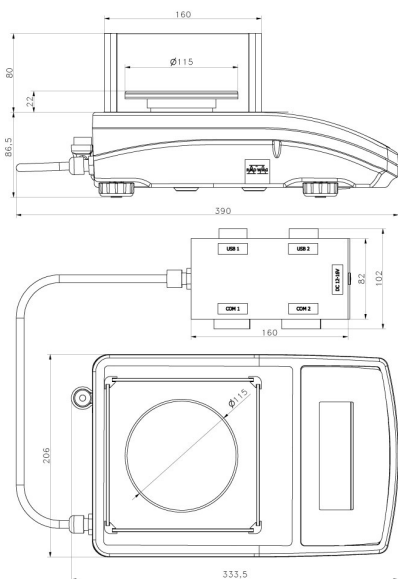

PS R2.H, d = 1 mg

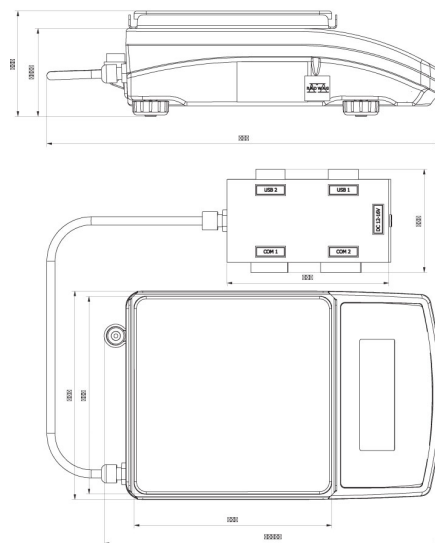

PS R2.M.H, d = 10 mg