



More information on the website
mirror.radwag.com/en/info,w1,FOM

MAS.1.82/220.R Weighing Module

WX-016-0165



The drawings, photos and graphics used are for illustrative purposes only.

Datasheet

Metrological parameters	
Maximum capacity [Max]	82 / 220 g
Minimum load	1 mg
Preload range	8.2 g
Readability [d]	0.01 / 0.1 mg
Tare range	-220 g
Minimum weight (USP)	40 mg
Minimum weight (U=1%,k=2)	4 mg
Repeatability (Max)	0.1 mg
Repeatability (5% Max)	0.02 mg
Linearity	±0.06 / 0.2 mg
Stabilization time	6 / 2 s
Physical parameters	
Display	LCD (backlit)
Weighing pan dimensions	ø42 mm
Device dimensions	289×143×125 mm

Physical parameters	
Packaging dimensions	650×340×315 mm
Net weight	4.7 kg
Gross weight	6.7 kg
Construction	
Protection class	IP 54
Communication interface	
Communication interface	RS232
Electrical parameters	
Power supply	100 – 240 V AC 50/60 Hz
Environmental conditions	
Operating temperature	+10 – +40 °C
Relative humidity	40% – 80%



Accessories (Additional Fee)

RS 232 cables (scale - printer)
 Antivibration Tables
 RS 232, RS 485 cables

Professional Weighing Tables
 RS 232 – USB Converter
 RS 232, RS 485 cables

Software (Additional Fee)

- RAD Key [WX-010-0005]
- R-Lab [WX-010-0080]

- R-Panel [WX-010-0187]
- RADWAG Development Studio [WX-010-0104]

Device dimensions



MAS.1
MAS.1.R



MAS.1

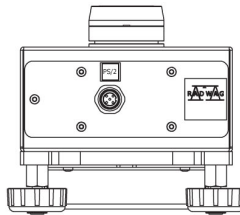

MAS.1.Y

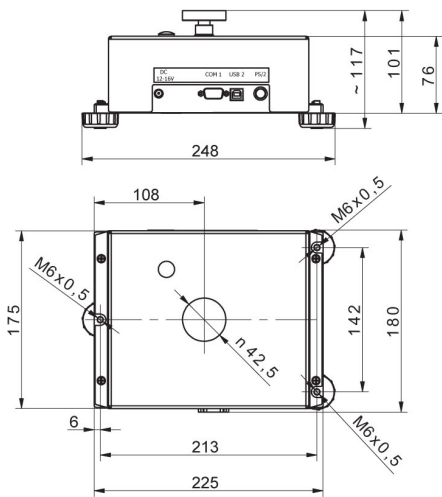

MAS

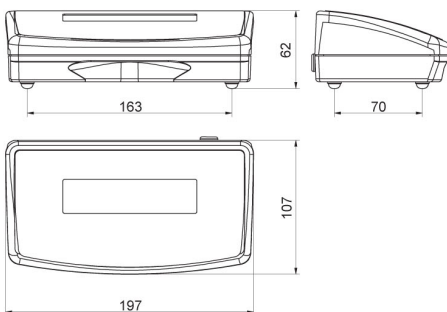

R operator panel



Y operator panel