



More information on the website  
[mirror.radwag.com/tr/info,w1,EHG](http://mirror.radwag.com/tr/info,w1,EHG)

# C315.1,5.F1.K Yük Hücreli Platform Terazı

WP-123-0002



The drawings, photos and graphics used are for illustrative purposes only.

## Fonksiyonlar

 Plus/Minus Control

 Percent Weighing

 Totalizing

 Parts counting

 Internal battery

 Peak hold

 Newton unit measurement

 GLP Procedures

 Animal weighing

 ALIBI Memory

## Teknik Veriler

### Metrolojik parametreler

Maksimum yük [Max]	1,5 kg
Minimum yük [Min]	10 g
Okuma için doğruluğu [d]	0,5 g
Yasallaştırma birimi [e]	0,5 g
Dara aralığı	-1,5 kg
Ticari amaçla kullanılmayan terazi için maksimum hassasiyet	0,2 g
OIML sınıfı	III

Fiziksel parametreler	
Display	4,3" LCD (aydınlatma ile)
Kablo uzunluğu	1 m
Tartım kefesi boyutları	300×300 mm
Ambalaj boyutları G x D x Y	570×390×170 mm
Net ağırlık	5,3 kg
Brüt ağırlık	5,5 kg
Konstrüksiyon	
IP Sınıfı	IP 65 konstrüksiyon, IP 43 terminal
Konstrüksiyon	toz kaplı çelik St3S
Tartım kefesi	Paslanmaz çelik AISI304
Haberleşme arayüzler	
Haberleşme arayüzü	RS232
Opsiyonel arayüzler	RS232
Elektrik parametreleri	
Güç kaynağı	100 – 240 V AC 50/60 Hz + batarya
Maksimum güç tüketimi	5 W
Batarya ile çalışma süresi	max 8h
Çevresel koşullar	
Çalıştırma sıcaklığı	-10 – +40 °C
Depolama sıcaklığı	-10 – +50 °C
Atmosferik nem	10% – 85% RH yoğunlaşma yok
İndikatör	C315



Additional fee for verification



## Aksesuarlar (Additional Fee)

Antivibrasyon masaları  
Güç adaptörü  
RS 232 Kablolar (Teraziler - Yazıcı)  
Tartım terminalleri için tutucular  
Çakmak prizine uygun besleme kabloları  
Display  
RS 232, RS 485 Kabloları

RS 232 – Ethernet Dönüştürücü  
AP2-1 Güç döngüsü çıkışı  
RS 232 – USB Dönüştürücü  
Kablolar RS 232 (Teraziler - Yazıcı)  
RS 232 – RS 485 Dönüştürücü  
Fiş yazıcı

## Yazılım (Additional Fee)

• RAD Key [WX-010-0005]  
• Terazi Editörü - EWAG 2.1 [WX-010-0173]

• R-Lab [WX-010-0080]

# Cihaz boyutları G x D x Y

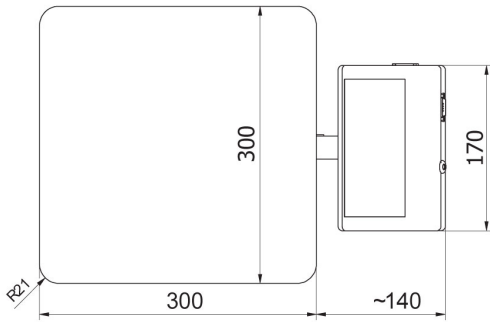

C315.F1.M

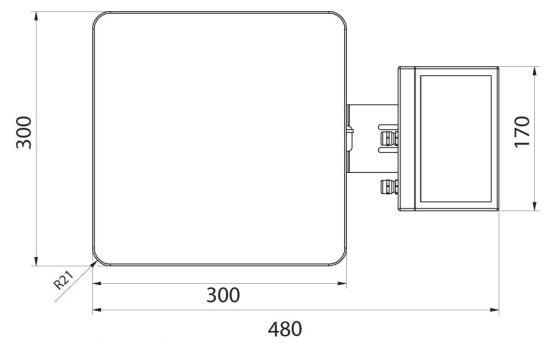

C315.F1.R

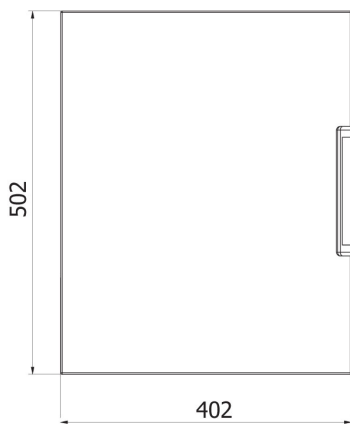

C315.C2.M

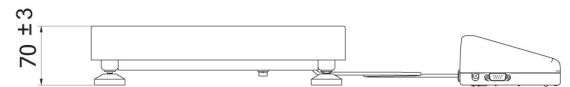

C315.C2.K