



More information on the website
mirror.radwag.com/en/info,w1,E90

SDKP DUAL Workstation for Pipettes Calibration

WL-101-0173



The drawings, photos and graphics used are for illustrative purposes only.

Datasheet

Physical parameters	
Delivery components	table for calibration, anti-vibration table ×2, probe for temperature, humidity and pressure measurement, probe for water temperature measurement, sink for used water, armrests, LCD monitor, PC with pre-installed software PIPETTES RADWAG, power supply, keyboard and mouse, container for used water
Chamber packaging size	820×1410×1000 mm
Gross weight	250 kg
Length	1350 mm
Width	750 mm
Height	1100 mm
Number of workstations	2

Compatible with (Additional Fee)

MYA 5Y.P Microbalance for pipettes calibration
AS X7 Analytical Balance
AS X2 PLUS Analytical Balances
Pipette Tips

AS 5Y Analytical Balance
AS R2 PLUS Analytical Balance
AS R1 PLUS Analytical Balance
THBR 2.0 System - Ambient Conditions Monitoring

Device dimensions

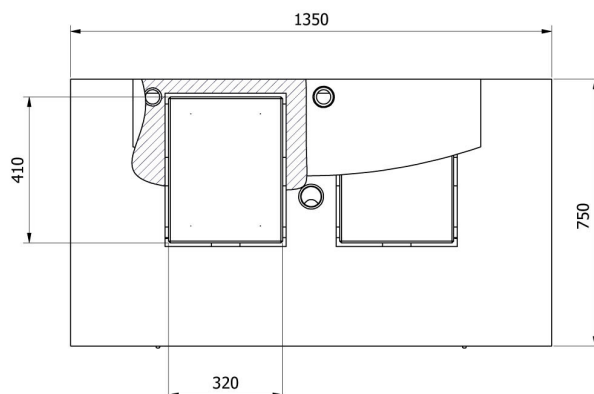
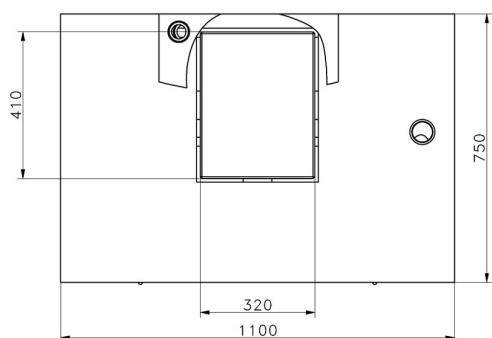
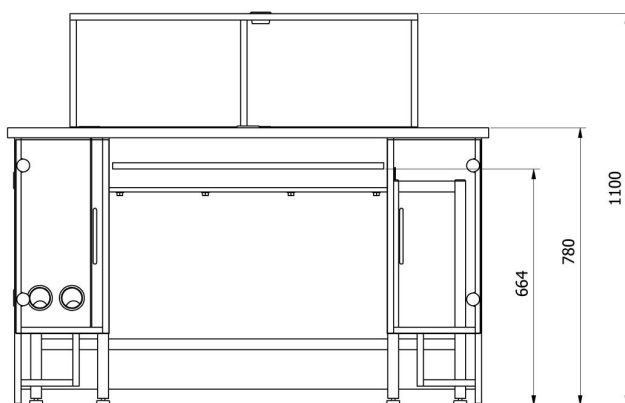
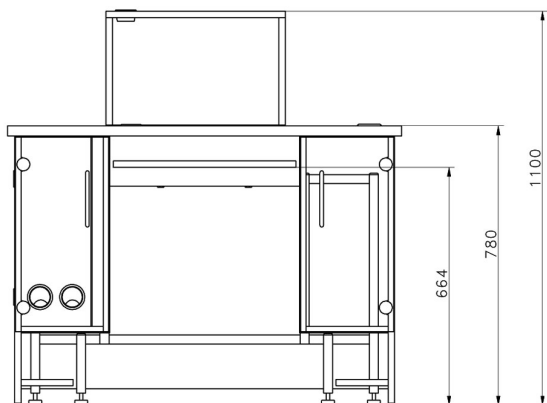

—SDKP

—SDKP DUAL