



More information on the website
mirror.radwag.com/de/info,w1,DI5

Wägemodul MAS.1.51.Y



The drawings, photos and graphics used are for illustrative purposes only.

Technische Daten

Messtechnische Parameter	
Wägebereich [Max]	51 g
Min. Belastung	1 mg
Zifferschritt [d]	0,01 mg
Tarierbereich	-51 g
Min. Einwaage USP	24 mg
Min. Einwaage (U=1%,k=2)	2,4 mg
Wiederholbarkeit (Max)	0,025 mg
Wiederholbarkeit (5% Max)	0,012 mg
Linearität	±0,06 mg
Stabilisierungszeit	6 s
Physikalische Parameter	
Display	5,7" Resistiv-Farb-Touchscreen
Waagschale	ø33 mm
Abmessungen des Geräts	289×143×125 mm
Verpackungsgröße	650×340×315 mm

Physikalische Parameter	
Nettogewicht	4,7 kg
Bruttogewicht	6,7 kg
Konstruktion	
Schutzart	IP 54
Kommunikationsschnittstellen	
Schnittstellen	2×RS232, 2×USB-A, Ethernet, 4 IN / 4 OUT (Digitalausgang), Wi-Fi
Elektrische Parameter	
Stromversorgung	100 – 240 V AC 50/60 Hz
Umgebungsbedingungen	
Umgebungstemperatur	+10 – +40 °C
Relative Luftfeuchtigkeit	40% – 80%

* Wi-Fi® is a registered trademark of Wi-Fi® Alliance.



Zubehör

Antivibrationstische
 Professionelle Wägestationen
 Kabel RS 232, RS 485

Konverter RS 232 – USB
 Kabel RS 232 (Waage – Drucker)

Software

- RAD Key [WX-010-0005]
- RLAB [WX-010-0080]

- R Panel [WX-010-0187]
- RADWAG Development Studio [WX-010-0104]

Abmessungen des Geräts

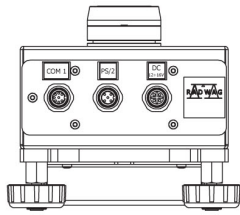

MAS.1
MAS.1.R

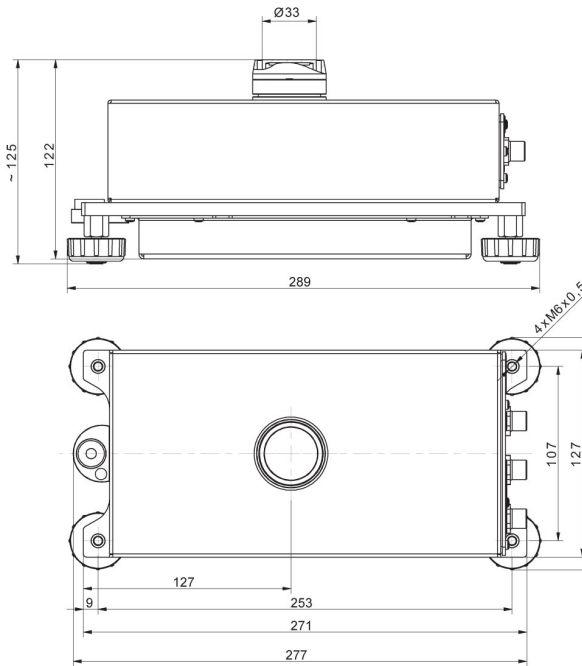

MAS.1

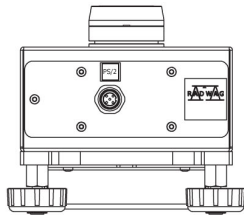

MAS.1.Y

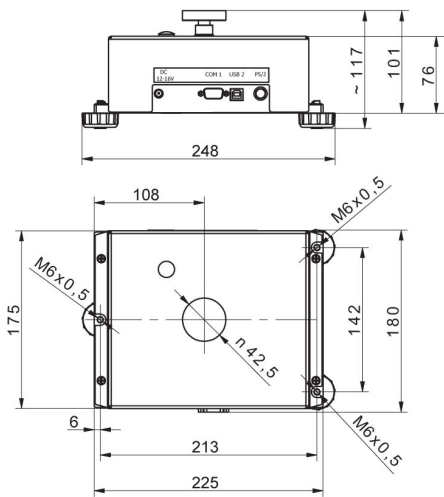

MAS

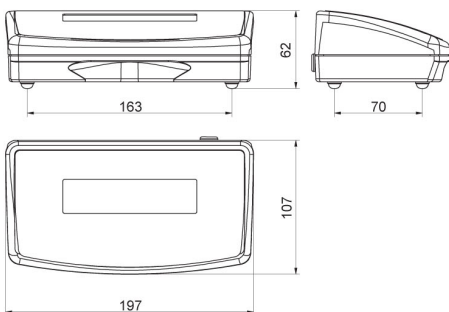

R operator panel

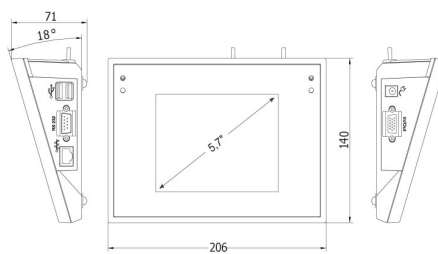

Y operator panel